

# User's Manual

## PMM L3-32

## PMM L3-64

## PMM L3-64/690

## PMM L3-100

## PMM L1-500

## PMM L3-500

## ARTIFICIAL MAINS NETWORKS

## PMM SBRF4

## RF SWITCHING BOX

### SERIAL NUMBER OF THE INSTRUMENT

You can find the Serial Number on the rear panel of the instrument.

Serial Number is in the form: 0000X00000.

The first four digits and the letter are the Serial Number prefix, the last five digits are the Serial Number suffix. The prefix is the same for identical instruments, it changes only when a configuration change is made to the instrument.

The suffix is different for each instrument.

**NOTE:**

® Names and Logo are registered trademarks of Narda Safety Test Solutions GmbH – Trade names are trademarks of the owners.



If the instrument is used in any other way than as described in this User's Manual, it may become unsafe.

Before using this product, the related documentation must be read with great care and fully understood to familiarize with all the safety prescriptions.

To ensure the correct use and the maximum safety level, the User shall know all the instructions and recommendations contained in this document.



This product is a **Safety Class I** instrument according to IEC classification and has been designed to meet the requirements of EN61010-1 (Safety Requirements for Electrical Equipment for Measurement, Control and Laboratory Use).

In accordance with the IEC classification, the power supply of this product meets requirements **Safety Class II** and **Installation Category II** (having double insulation and able to carry out mono-phase power supply operations).

It complies with the requirements of **Pollution Class II** (usually only non-conductive pollution). However, occasionally it may become temporarily conductive due to condense on it.

The information contained in this document is subject to change without notice.

**EXPLANATION OF ELECTRICAL AND SAFETY SYMBOLS :**

 You now own a high-quality instrument that will give you many years of reliable service. Nevertheless, even this product will eventually become obsolete. When that time comes, please remember that electronic equipment must be disposed of in accordance with local regulations. This product conforms to the WEEE Directive of the European Union (2002/96/EC) and belongs to Category 9 (Monitoring and Control Instruments). You can return the instrument to us free of charge for proper environment friendly disposal. You can obtain further information from your local Narda Sales Partner or by visiting our website at [www.narda-sts.it](http://www.narda-sts.it).



Warning, danger of electric shock



Earth



Read carefully the Operating Manual and its instructions, pay attention to the safety symbols.



Unit Earth Connection



Earth Protection



Equipotential

**EXPLANATION OF SYMBOLS USED IN THIS DOCUMENT :**



The DANGER sign draws attention to a serious risk to a person's safety, which, if not avoided, will result in death or serious injury. All the precautions must be fully understood and applied before proceeding.



The WARNING sign indicates a hazardous situation, which, if not avoided, could result in death or serious injury. All the precautions must be fully understood and applied before proceeding.



The CAUTION sign indicates a hazardous situation, which, if not avoided, could result in minor or moderate injury.



The NOTICE sign draws attention to a potential risk of damage to the apparatus or loss of data.



The NOTE sign draws attention to important information.



EC Conformity

# Contents

<b>Safety considerations and instructions .....</b>	<b>Page</b> V
<b>EC Declaration of Conformity PMM L3-32.....</b>	VII
<b>EC Declaration of Conformity PMM L3-64.....</b>	VIII
<b>EC Declaration of Conformity PMM L3-64/690 .....</b>	IX
<b>EC Declaration of Conformity PMM L3-100 .....</b>	X
<b>EC Declaration of Conformity PMM L1-500.....</b>	XI
<b>EC Declaration of Conformity PMM L3-500.....</b>	XII
<b>EC Declaration of Conformity PMM SBRF4 .....</b>	XIII
<b>1 General Information</b>	<b>Page</b>
1.1 Documentation.....	1-1
1.2 Introduction to PMM Artificial Mains Network.....	1-1
1.3 PMM Artificial Mains Networks for “CURRENT INJECTION” test.	1-2
1.4 Shipping components.....	1-3
1.5 Optional accessories.....	1-3
1.6 Environment.....	1-3
1.7 Return for service.....	1-4
1.8 Equipment cleaning.....	1-4
<b>2 PMM L3-32</b>	<b>Page</b>
2.1 Main specifications.....	2-1
2.2 Front and Rear panels.....	2-2
<b>3 PMM L3-64 and L3-64/690</b>	<b>Page</b>
3.1 L3-64 Main specifications .....	3-1
3.2 L3-64/690 Main specifications .....	3-2
3.3 Front and Rear panels.....	3-3
<b>4 PMM L3-100</b>	<b>Page</b>
4.1 Main specifications.....	4-1
4.2 Front and Rear panels.....	4-2
<b>5 PMM L3-500</b>	<b>Page</b>
5.1 Main specifications.....	5-1
5.2 Front and Rear panels.....	5-3
<b>6 Installation</b>	<b>Page</b>
6.1 Introduction.....	6-1
6.2 Initial inspection.....	6-1
6.3 Packing unpacking.....	6-1
6.4 Preparation for use.....	6-2
6.5 Pilot Circuit.....	6-2
6.6 Installation check list.....	6-3
<b>7 Operating PMM Artificial Mains Networks</b>	<b>Page</b>
7.1 Operating PMM Networks.....	7-1
7.2 Test Set-Up Considerations.....	7-2
7.3 Network verification and maintenance.....	7-3
7.4 Remote receiver control connector.....	7-4
7.5 LISN remote cable Configuration for PMM 9010F.....	7-5
7.6 LISN remote cable Configuration for PMM 8010.....	7-6
<b>8 Accessories</b>	<b>Page</b>
8.1 PMM SBRF4 RF Switching Box (optional).....	8-1
Introduction.....	8-1
Specifications.....	8-2
Instrument Items.....	8-2
Other accessories.....	8-2
Housing.....	8-3
System configuration.....	8-4
Installation and use.....	8-5

## Figures

Figure		Page
1-1	CISPR 16 equivalent circuit.....	1-2
2-1	PMM L3-32 Front Panel.....	2-2
2-2	PMM L3-32 Rear Panel.....	2-2
3-1	PMM L3-64 Front Panel.....	3-2
3-2	PMM L3-64 Rear Panel.....	3-2
4-1	PMM L3-100 Front Panel.....	4-2
4-2	PMM L3-100 Rear Panel.....	4-2
5-1	PMM L3-500 .....	5-1
5-2	PMM L1-500 .....	5-2
5-3	PMM L3-500 Front Panel.....	5-3
5-4	PMM L3-500 Rear Panel.....	5-4
5-5	Contactors diagram.....	5-4
5-6	Four rear ground connectors connection.....	5-5
5-7	L1-500 (same as each L3-500) equivalent circuit	5-6
6-1	Pilot circuit connection example.....	6-2
7-1	Typical test set-up.....	7-2
7-2	“Remote Control” connector (Front view).....	7-4
7-3	LISN remote cable configuration for PMM 9010F.....	7-5
7-4	LISN remote cable configuration for PMM 8010.....	7-6
8-1	PMM SBRF4 RF Switching Box.....	8-1
8-2	PMM SBRF4 Front view.....	8-3
8-3	PMM SBRF4 Right view.....	8-3
8-4	PMM SBRF4 Left view.....	8-3
8-5	PMM SBRF4 with external Artificial Mains Network.....	8-4
8-6	PMM SBRF4 with RF300 Large Loop Antenna.....	8-4

## Tables

Table		Page
2-1	Main Specifications PMM L3-32.....	2-1
3-1	Main Specifications PMM L3-64.....	3-1
4-1	Main Specifications PMM L3-100.....	4-1
5-1	Main Specifications PMM L3-500.....	5-1
8-1	Technical Specifications of SBRF4.....	8-2

** WARNING SAFETY RECOMMENDATIONS AND INSTRUCTIONS**

This product has been designed, produced and tested in Italy, and it left the factory in conditions fully complying with the current safety standards. To maintain it in safe conditions and ensure correct use, these general instructions must be fully understood and applied before the product is used.

- This is an industrial instrument for special EMC test purposes and should be installed and operated by qualified, authorized and trained personnel only.
- High magnetic fields are present around the instrument when used at high currents. It is highly recommended not to approach the machine when in operation, and especially forbidden for people with pacemakers or other electromedical devices.
- Over current protection is not provided in the LISN. The LISN must be connected to a power mains which has the properly rated mains protection installed.
- When the device must be connected, first provide effective grounding;
- If the device must be connected to other equipment or accessories, make sure they are all safely grounded;
- In case of devices permanently connected to the power supply, and lacking any fuses or other devices of mains protection, the power line must be equipped with adequate protection commensurate to the consumption of all the devices connected to it;
- In case of connection of the device to the power mains, make sure before connection that the voltage selected on the voltage switch and the fuses are adequate for the voltage of the actual mains;
- Devices in Safety Class I, equipped with connection to the power mains by means of cord and plug, can only be plugged into a socket equipped with a ground wire;
- Any interruption or loosening of the ground wire or of a connecting power cable, inside or outside the device, will cause a potential risk for the safety of the personnel;
- Ground connections must not be interrupted;
- To prevent the possible danger of electrocution, do not remove any covers, panels or guards installed on the device, and refer only to NARDA Service Centers if maintenance should be necessary;
- To maintain adequate protection from fire hazards, replace fuses only with others of the same type and rating;
- Follow the safety regulations and any additional instructions in this manual to prevent accidents and damages.
- The probe cannot be handled in proximity of high voltage mains line.
- If the probe is to be connected to high voltage mains line a safety interlock equipment must be installed to ensure the mains line be switched off before any probe handling or connection;

- The user must provide a safety protection cover with a low voltage interlock switch able to cut off mains voltage before probe handling or connection.
- The leakage currents between the phases and the earth line generally exceed permitted limits for typical environments, due to internal capacitors; for this reason it is mandatory to use a current rated insulating transformer to supply the LISN.
- Make sure before connecting the power mains that the voltage and the fuses are appropriate to the actual mains.
- Always connect the Contactors output, where provided, to a safety interlock system, to ensure the mains line be switched off when the temperature overpasses a predetermined threshold.
- Pay attention to the hot surfaces. The temperatures of the external panels and covers can reach dangerous levels when using the apparatus at high currents.
- All power cords must be connected to ensure proper ventilation and control of the contactors.
- Where Front and Back EUT LINE IN and OUT are constituted by bolts, covered by a plastic protection. It is very important to connect all the cables and mount the plastic covers before applying power to the lines. After the connection is made it becomes very dangerous to approach and touch the wire connections, even if protected by the covers.
- It is important to create a security zone around the instrument (at least 1.5m) where no one should go in while the test is in progress.
- Since improper or careless operation could result in an injury risk, these operating instructions make an essential part of the device and must be available to the operator at all times. The user must satisfy all safety instructions and warnings.
- To tighten the nuts of the power lines use only the wrench supplied.
- Do not force the tightening of the nuts.

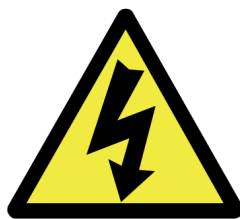

# Dichiarazione di Conformità *EU Declaration of Conformity*



In accordo alla Decisione 768/2008/EC, conforme alle direttive EMC 2014/30/UE, Bassa Tensione 2014/35/UE e RoHS 2011/65/UE, ed anche alle norme ISO/IEC 17050-1 e 17050-2.

*In accordance with the Decision 768/2008/EC, compliant to the Directives EMC 2014/30/EU, Low Voltage 2014/35/EU and RoHS 2011/65/EU, also compliant to the ISO/IEC standard 17050-1 and 17050-2*

Il costruttore  
*The manufacturer*

**narda Safety Test Solutions S.r.l. Socio Unico**

Indirizzo  
*Address*

**Via Benessea, 29 / B**

**I-17035 Cisano sul Neva (SV) - Italy**

**sulla base delle seguenti norme europee armonizzate, applicate con esito positivo:  
*based on the following harmonized European Standards, successfully applied:***

EMC - Emissioni:  
*EMC - Emission:*

**IEC EN 61326-1 (2021)**

EMC - Immunità:  
*EMC - Immunity:*

**IEC EN 61326-1 (2021)**

Sicurezza:  
*Safety:*

**EN 61010-1 (2010)**

**dichiara, sotto la propria responsabilità, che il prodotto:  
*declares, under its sole responsibility, that the product:***

Descrizione  
*Description*

**RETE ARTIFICIALE  
*ARTIFICIAL MAINS NETWORK***

Modello  
*Model*

**L3-32**

**è conforme ai requisiti essenziali delle seguenti Direttive:  
*conforms with the essential requirements of the following Directives:***

Bassa Tensione  
*Low Voltage*

**2014/35/EU**

Compatibilità Elettromagnetica  
*EMC*

**2014/30/EU**

RoHS  
*RoHS*

**2011/65/EU**

**Cisano sul Neva, 7 June 2023**

**Egon Stocca  
General Manager**

# Dichiarazione di Conformità *EU Declaration of Conformity*

In accordo alla Decisione 768/2008/EC, conforme alle direttive EMC 2014/30/UE, Bassa Tensione 2014/35/UE e RoHS 2011/65/UE, ed anche alle norme ISO/IEC 17050-1 e 17050-2.  
*In accordance with the Decision 768/2008/EC, compliant to the Directives EMC 2014/30/EU, Low Voltage 2014/35/EU and RoHS 2011/65/EU, also compliant to the ISO/IEC standard 17050-1 and 17050-2*

Il costruttore  
*The manufacturer* **narda Safety Test Solutions S.r.l. Socio Unico**

Indirizzo  
*Address* **Via Benessea, 29 / B**

**I-17035 Cisano sul Neva (SV) - Italy**

**sulla base delle seguenti norme europee armonizzate, applicate con esito positivo:**  
***based on the following harmonized European Standards, successfully applied:***

EMC - Emissioni:  
*EMC - Emission:* **IEC EN 61326-1 (2021)**

EMC - Immunità:  
*EMC - Immunity:* **IEC EN 61326-1 (2021)**

Sicurezza:  
*Safety:* **EN 61010-1 (2010)**

**dichiara, sotto la propria responsabilità, che il prodotto:**  
***declares, under its sole responsibility, that the product:***

Descrizione  
*Description* **RETE ARTIFICIALE  
ARTIFICIAL MAINS NETWORK**

Modello  
*Model* **L3-64**

**è conforme ai requisiti essenziali delle seguenti Direttive:**  
***conforms with the essential requirements of the following Directives:***

Bassa Tensione  
*Low Voltage* **2014/35/EU**

Compatibilità Elettromagnetica  
*EMC* **2014/30/EU**

RoHS  
*RoHS* **2011/65/EU**

**Cisano sul Neva, 7 June 2023**

**Egon Stocca  
General Manager**





# Dichiarazione di Conformità *EU Declaration of Conformity*



In accordo alla Decisione 768/2008/EC, conforme alle direttive EMC 2014/30/UE, Bassa Tensione 2014/35/UE e RoHS 2011/65/UE, ed anche alle norme ISO/IEC 17050-1 e 17050-2.

*In accordance with the Decision 768/2008/EC, compliant to the Directives EMC 2014/30/EU, Low Voltage 2014/35/EU and RoHS 2011/65/EU, also compliant to the ISO/IEC standard 17050-1 and 17050-2*

Il costruttore  
*The manufacturer*

**narda Safety Test Solutions S.r.l. Socio Unico**

Indirizzo  
*Address*

**Via Benessea, 29 / B**

**I-17035 Cisano sul Neva (SV) - Italy**

**sulla base delle seguenti norme europee armonizzate, applicate con esito positivo:**  
***based on the following harmonized European Standards, successfully applied:***

EMC - Emissioni:  
*EMC - Emission:*

**IEC EN 61326-1 (2021)**

EMC - Immunità:  
*EMC - Immunity:*

**IEC EN 61326-1 (2021)**

Sicurezza:  
*Safety:*

**EN 61010-1 (2010)**

**dichiara, sotto la propria responsabilità, che il prodotto:**  
***declares, under its sole responsibility, that the product:***

Descrizione  
*Description*

**RETE ARTIFICIALE  
*ARTIFICIAL MAINS NETWORK***

Modello  
*Model*

**L3-64/690**

**è conforme ai requisiti essenziali delle seguenti Direttive:**  
***conforms with the essential requirements of the following Directives:***

Bassa Tensione  
*Low Voltage*

**2014/35/EU**

Compatibilità Elettromagnetica  
*EMC*

**2014/30/EU**

RoHS  
*RoHS*

**2011/65/EU**

**Cisano sul Neva, 7 June 2023**

**Egon Stocca**

**General Manager**

# Dichiarazione di Conformità *EU Declaration of Conformity*

In accordo alla Decisione 768/2008/EC, conforme alle direttive EMC 2014/30/UE, Bassa Tensione 2014/35/UE e RoHS 2011/65/UE, ed anche alle norme ISO/IEC 17050-1 e 17050-2.  
*In accordance with the Decision 768/2008/EC, compliant to the Directives EMC 2014/30/EU, Low Voltage 2014/35/EU and RoHS 2011/65/EU, also compliant to the ISO/IEC standard 17050-1 and 17050-2*

Il costruttore  
*The manufacturer* **narda Safety Test Solutions S.r.l. Socio Unico**

Indirizzo  
*Address* **Via Benessea, 29 / B**

**I-17035 Cisano sul Neva (SV) - Italy**

**sulla base delle seguenti norme europee armonizzate, applicate con esito positivo:**  
***based on the following harmonized European Standards, successfully applied:***

EMC - Emissioni:  
*EMC - Emission:* **IEC EN 61326-1 (2021)**

EMC - Immunità:  
*EMC - Immunity:* **IEC EN 61326-1 (2021)**

Sicurezza:  
*Safety:* **EN 61010-1 (2010)**

**dichiara, sotto la propria responsabilità, che il prodotto:**  
***declares, under its sole responsibility, that the product:***

Descrizione  
*Description* **RETE ARTIFICIALE  
ARTIFICIAL MAINS NETWORK**

Modello  
*Model* **L3-100**

**è conforme ai requisiti essenziali delle seguenti Direttive:**  
***conforms with the essential requirements of the following Directives:***

Bassa Tensione  
*Low Voltage* **2014/35/EU**

Compatibilità Elettromagnetica  
*EMC* **2014/30/EU**

RoHS  
*RoHS* **2011/65/EU**

**Cisano sul Neva, 7 June 2023**

**Egon Stocca  
General Manager**



**X**

**EC Conformity**

# Dichiarazione di Conformità *EU Declaration of Conformity*



In accordo alla Decisione 768/2008/EC, conforme alle direttive EMC 2014/30/UE, Bassa Tensione 2014/35/UE e RoHS 2011/65/UE, ed anche alle norme ISO/IEC 17050-1 e 17050-2.

*In accordance with the Decision 768/2008/EC, compliant to the Directives EMC 2014/30/EU, Low Voltage 2014/35/EU and RoHS 2011/65/EU, also compliant to the ISO/IEC standard 17050-1 and 17050-2*

Il costruttore  
*The manufacturer*

**narda Safety Test Solutions S.r.l. Socio Unico**

Indirizzo  
*Address*

**Via Benessea, 29 / B**

**I-17035 Cisano sul Neva (SV) - Italy**

**sulla base delle seguenti norme europee armonizzate, applicate con esito positivo:**  
***based on the following harmonized European Standards, successfully applied:***

EMC - Emissioni:  
*EMC - Emission:*

**IEC EN 61326-1 (2021)**

EMC - Immunità:  
*EMC - Immunity:*

**IEC EN 61326-1 (2021)**

Sicurezza:  
*Safety:*

**EN 61010-1 (2010)**

**dichiara, sotto la propria responsabilità, che il prodotto:**  
***declares, under its sole responsibility, that the product:***

Descrizione  
*Description*

**RETE ARTIFICIALE  
*ARTIFICIAL MAINS NETWORK***

Modello  
*Model*

**L1-500**

**è conforme ai requisiti essenziali delle seguenti Direttive:**  
***conforms with the essential requirements of the following Directives:***

Bassa Tensione  
*Low Voltage*

**2014/35/EU**

Compatibilità Elettromagnetica  
*EMC*

**2014/30/EU**

RoHS  
*RoHS*

**2011/65/EU**

**Cisano sul Neva, 7 June 2023**

**Egon Stocca**

**General Manager**

**EC Conformity**

**XI**

# Dichiarazione di Conformità *EU Declaration of Conformity*

In accordo alla Decisione 768/2008/EC, conforme alle direttive EMC 2014/30/UE, Bassa Tensione 2014/35/UE e RoHS 2011/65/UE, ed anche alle norme ISO/IEC 17050-1 e 17050-2.

*In accordance with the Decision 768/2008/EC, compliant to the Directives EMC 2014/30/EU, Low Voltage 2014/35/EU and RoHS 2011/65/EU, also compliant to the ISO/IEC standard 17050-1 and 17050-2*

Il costruttore  
*The manufacturer* **narda Safety Test Solutions S.r.l. Socio Unico**

Indirizzo  
*Address* **Via Benessea, 29 / B**

**I-17035 Cisano sul Neva (SV) - Italy**

**sulla base delle seguenti norme europee armonizzate, applicate con esito positivo:**  
*based on the following harmonized European Standards, successfully applied:*

EMC - Emissioni:  
*EMC - Emission:* **IEC EN 61326-1 (2021)**

EMC - Immunità:  
*EMC - Immunity:* **IEC EN 61326-1 (2021)**

Sicurezza:  
*Safety:* **EN 61010-1 (2010)**

**dichiara, sotto la propria responsabilità, che il prodotto:**  
*declares, under its sole responsibility, that the product:*

Descrizione  
*Description* **RETE ARTIFICIALE  
ARTIFICIAL MAINS NETWORK**

Modello  
*Model* **L3-500**

**è conforme ai requisiti essenziali delle seguenti Direttive:**  
*conforms with the essential requirements of the following Directives:*

Bassa Tensione  
*Low Voltage* **2014/35/EU**

Compatibilità Elettromagnetica  
*EMC* **2014/30/EU**

RoHS  
*RoHS* **2011/65/EU**

**Cisano sul Neva, 7 June 2023**

**Egon Stocca  
General Manager**



# Dichiarazione di Conformità *EC Declaration of Conformity*



In accordo alla Decisione 768/2008/EC, conforme alle direttive EMC 2014/30/UE, Bassa Tensione 2014/35/UE e RoHS 2011/65/UE, ed anche alle norme ISO/IEC 17050-1 e 17050-2.

*In accordance with the Decision 768/2008/EC, compliant to the Directives EMC 2014/30/UE, Low Voltage 2014/35/UE and RoHS 2011/65/EU, also compliant to the ISO/IEC standard 17050-1 and 17050-2*

Il costruttore  
*The manufacturer*

**narda Safety Test Solutions S.r.l. Socio Unico**

Indirizzo  
*Address*

**Via Benessea, 29 / B**

**I-17035 Cisano sul Neva (SV) - Italy**

**sulla base delle seguenti norme europee armonizzate, applicate con esito positivo:  
*based on the following harmonized European Standards, successfully applied:***

EMC - Emissioni:  
*EMC - Emission:*

**IEC EN 61326-1 (2021)**

EMC - Immunità:  
*EMC - Immunity:*

**IEC EN 61326-1 (2021)**

Sicurezza:  
*Safety:*

**EN 61010-1 (2010)**

**dichiara, sotto la propria responsabilità, che il prodotto:  
*declares, under its sole responsibility, that the product:***

Descrizione  
*Description*

**COMMUTATORE RF  
RF SWITCHING BOX**

Modello  
*Model*

**PMM SBRF4**

**è conforme ai requisiti essenziali delle seguenti Direttive:  
*conforms with the essential requirements of the following Directives:***

Bassa Tensione  
*Low Voltage*

**2014/35/EU**

Compatibilità Elettromagnetica  
*EMC*

**2014/30/EU**

RoHS  
*RoHS*

**2011/65/EU**

**Cisano sul Neva, 14 March 2024**

**Egon Stocca**

**General Manager**

**This page has been left blank intentionally**

# 1 - General Information

---

## 1.1 Documentation

Enclosed with this manual are a service questionnaire to send back to NARDA in case of equipment service is needed, and an accessories check list to verify all accessories enclosed in the packaging.

## 1.2 Introduction to PMM Artificial Mains Networks

The objective of EMI Conducted tests is to define the amplitude of current  $I_c$  and Voltage  $V_c$  emission from the Device Under Test (DUT) onto the power mains or to define the immunity of the DUT to the conducted interference.

The mains lines themselves do not allow for reliable EMI measurements since their impedance is subject to marked variations that generates different test results at different test sites.

The PMM Artificial Mains Networks are LISN used for RFI measurements on AC three-phase, power supplied electric and electronic equipment usable from DC to 60 Hz.

The LISNs are three line V-network with an equivalent circuit of 50 ohm // (5ohm + 50 $\mu$ H), fully compliant with CISPR publ. 16, VDE 0876 and FCC part 15 regulation.

The LISNs are suited to perform measurements on conducted interference in the frequency range from 9 kHz to 30 MHz.

Designed according to criteria of cheaply and compactness they can be used together with PMM Systems for Conducted Interference or 9010F, ER8000, ER9000 or any other RF receiver.

The main functions performed by the Artificial Mains Network are:

- terminate the DUT with a standardized impedance against reference ground;
- supply power to the DUT;
- insulate the test circuits against external interference coming, for example, from AC-voltage network;
- route the EMI (Electro Magnetic Interference) of the DUT to the receiver, in case of conducted emission measurement, and the EMI from the signal generator to the DUT, in case of susceptibility test (current injection).

The PMM LISNs are provided with a standard industrial power sockets, with a pilot conductor connector provided.

According to EN 60309 (IEC 309) Normative the pilot conductor can be used to operate a remote control switch, to avoid any mains connector operation with high current load.

**1.3 PMM Artificial Mains  
Networks for  
“CURRENT  
INJECTION” test**

As described above, a LISN is primarily a probe to take out RF signals. Some particular EMC recommendations might require that Device Under Test shall be proven to conducted EMC immunity in the range 10 kHz – 30 MHz, by injecting on the supply lines certain RF interference and checking the DUT’s response.

PMM LISNs may be used also to this purpose by injecting a RF signal into the RF output connector on the front panel.

The following figure shows the CISPR equivalent circuit.

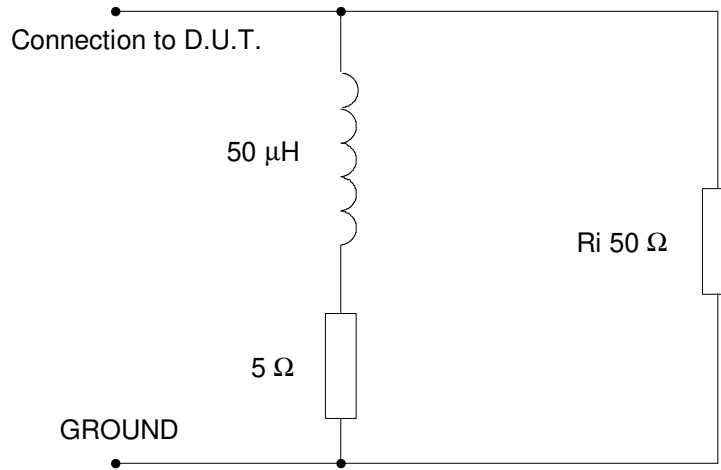

Ri = input impedance of the RFI

**CISPR equivalent circuit**

**Fig. 1-1** CISPR éivalent circuit



#### 1.4 Shipping components

The LISN L3-32, L3-64, L3-64/690V, L3-100 is composed by the following parts:

- PMM LISN Network
- Rear Mains Socket
- Front Mains Plug
- RF Cable
- LISN Control Cable for 9010F
- Software Media including user's manual
- Certificate of Compliance

The LISN L3-500 is composed by the following parts:

- n°4 PMM L1-500 Network
- Rack
- RF Cable
- Software Media including user's manual
- Power supply Cable
- RF BNC 50 Ohm Load
- Certificate of Compliance
- Contactors connectors

#### 1.5 Optional Accessories



PMM LISN Network can be used with:

- PMM SBRF4 RF Switching Box.
- LISN Service Kit (AC-BNC adapter for LISNs verification and calibration)

See "Annex D" 9010F User's manual as example.

#### 1.6 Environment

The operating environment is specified to be within the following limitations:

- Temperature -10° to +40° C
- Humidity < 90% relative

The instrument should be stored in a clean, dry environment

The storage and shipping environment is specified to be within the following limitations :

- Temperature -25° to + 75° C
- Humidity < 95% relative

### 1.7 Return for service

If the instrument should be returned to NARDA for service, please complete the service questionnaire enclosed with the Operating Manual and attach it to the instrument.

To minimize the repair time, be as specific as possible when describing the failure. If the failure only occurs under certain conditions, explain how to duplicate the failure.

If possible, reuse of the original packaging to ship the equipment is preferable.

In case other package should be used ensure to wrap the instrument in heavy paper or plastic.

Use a strong shipping container and use enough shock absorbing material around all sides of the equipment to provide a firm cushion and prevent movement in the container.

Seal the shipping container securely with shipment tape.

Mark the shipping container FRAGILE to encourage careful handling.

### 1.8 Equipment cleaning

Use a clean, dry non abrasive cloth for external cleaning of the equipment.

#### **NOTICE**

**To clean the equipment do not use any solvent, thinner, turpentine, acid, acetone or similar matter to avoid damage to external plastic and surfaces.**

## 2 – PMM L3-32



Table 2-1 lists the PMM L3-32 Network performance specifications. The following conditions apply to all specifications:

- The ambient temperature must be -10° to 40°.

### 2.1 Main specifications

TABLE 2-1 Main specifications PMM L3-32			
<b>Frequency range:</b>	9 kHz to 30 MHz		
<b>Maximum continuous rated output current:</b>	IEC plug: 32 A Schuko plug: 16 A		
<b>Maximum operating voltage</b>			
<b>Single-phase</b>	<b>(L/N) (L/PE) (N/PE):</b>	230 Vac	325 Vdc
<b>Three-phase</b>	<b>(L/PE) (N/PE):</b>	230 Vac	325 Vdc
	<b>(L/L) (L/N):</b>	400 Vac	565 Vdc
<b>Input Mains frequency range:</b>	DC - 60 Hz		
<b>Equivalent circuit:</b>	50 Ohm // (5 Ohm + 50 μH)		
<b>RF output:</b>	BNC female		
<b>Test item:</b>	32 A IEC connector and 16A Schuko		
<b>Rated temperature:</b>	-10° to + 40° C		
<b>Storage temperature:</b>	-25° to + 75° C		
<b>Overall dimension mm (W x H x D):</b>	342 x 254 x 510		
<b>Weight:</b>	16.5 kg		

## 2.2 Front and Rear Panels

In Fig. 2-1 and Fig. 2-2 you can see front and rear connecting points and terminals of PMM L3-32 Network.

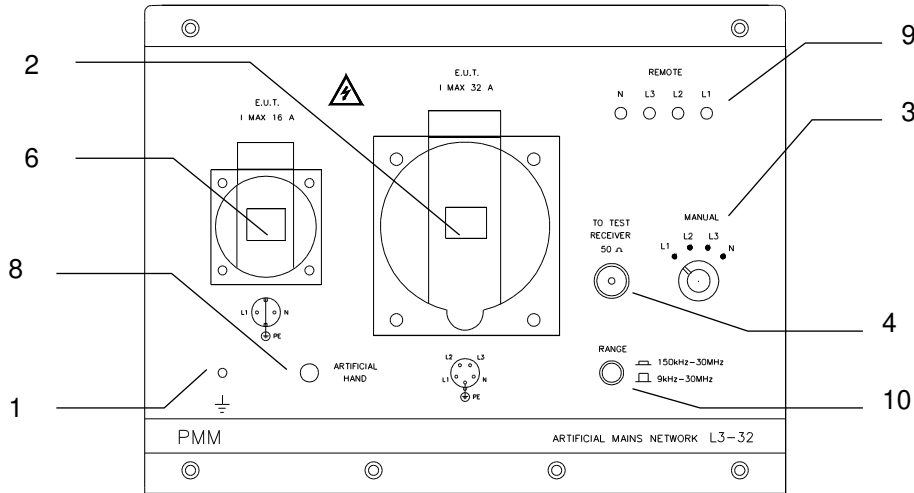

**Fig. 2-1 Front Panel**

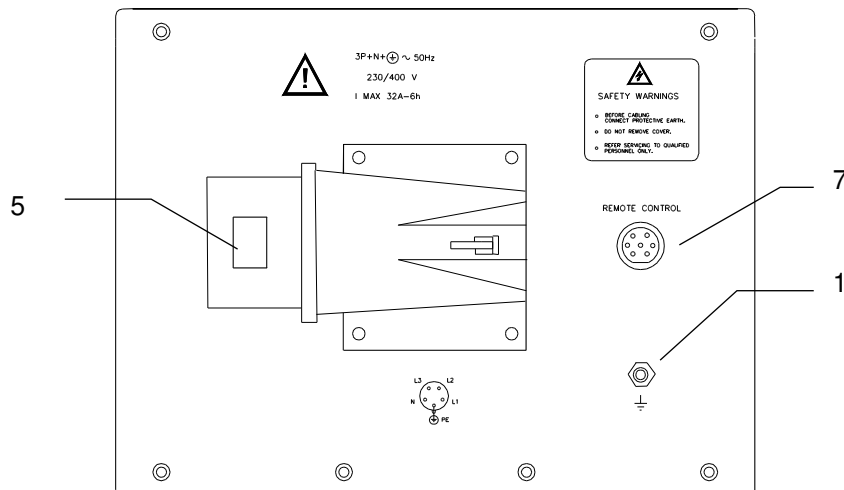

**Fig. 2-2 Rear Panel**

### Legend:

- |  |                                      |
|--|--------------------------------------|
| 1- Ground contact  | 5- Mains LISN supply.                |
| 2- Mains supply to DUT 32A   | 6- Mains supply to DUT 16A Schuko    |
| 3- Manual switch for phase under test (With PMM receivers the switch is disabled and the switching is automatic) | 7- Remote receiver control connector |
| 4- RF output to EMI Signal Analyzer (50 ohm, BNC female connector)   | 8- Artificial hand.                  |
|  | 9- Line under test indicating led.   |
|  | 10- Filter 150kHz-30MHz              |

## 3 – PMM L3-64 and L3-64/690



Table 3-1 lists the PMM L3-64 Network performance specifications. The following conditions apply to all specifications:

- The ambient temperature must be -10° to 40°.

### 3.1 L3-64 Main specifications

TABLE 3-1 Main specifications PMM L3-64			
<b>Frequency range:</b>	9 kHz to 30 MHz		
<b>Maximum rated output current:</b>	63 A		
<b>Maximum operating voltage</b>	<b>(L/PE) (N/PE):</b>	230 Vac	325 Vdc
	<b>(L/L) (L/N):</b>	400 Vac	565 Vdc
<b>Input mains frequency range:</b>	DC - 60 Hz		
<b>Equivalent circuit:</b>	50 Ohm // (5 Ohm + 50 μH) with 250 μH choke		
<b>RF output:</b>	BNC female		
<b>Test item:</b>	63 A IEC connector		
<b>Rated temperature:</b>	-10° to + 40° C		
<b>Storage temperature:</b>	- 25° to + 75° C		
<b>Overall dimension mm (W x H x D):</b>	465 x 450 x 740		
<b>Weight:</b>	50 kg		



Table 3-2 lists the PMM L3-64/690 Network performance specifications. The following conditions apply to all specifications:

- The ambient temperature must be -10° to 40°.

### 3.2 L3-64/690 Main specifications

<b>TABLE 3-2 Main specifications PMM L3-64/690</b>			
<b>Frequency range:</b>	9 kHz to 30 MHz		
	<i>standard</i>		
	<i>IEC60309</i>	<i>UL1682 UL1686</i>	
<b>Maximum rated input current:</b>	63 A	60 A	
<b>Maximum operating voltage</b>	<b>(L/PE) (N/PE):</b>	400 Vac 565 Vdc	347 Vac 490 Vdc
	<b>(L/L) (L/N):</b>	690 Vac 975 Vdc	600 Vac 850 Vdc
<b>EUT, main power supply:</b>	63 A black connector 4P5W		60 A black connector 4P5W
<b>Input mains frequency range:</b>	DC - 60 Hz		
<b>Equivalent circuit:</b>	50 Ohm // (5 Ohm + 50 μH) with 250 μH choke		
<b>RF output:</b>	BNC female		
<b>Rated temperature:</b>	-10° to + 40° C		
<b>Storage temperature:</b>	- 25° to + 75° C		
<b>Overall dimension mm (W x H x D):</b>	465 x 450 x 730		
<b>Weight:</b>	50 kg		

### 3.3 Front and Rear Panels

In Fig. 3-1 and Fig. 3-2 you can see front and rear connecting points and terminals of PMM L3-64 Network.

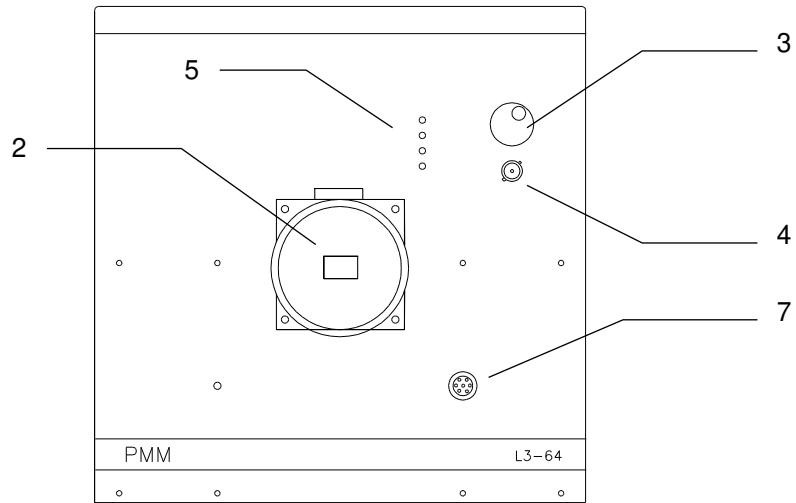

**Fig. 3-1** Front Panel

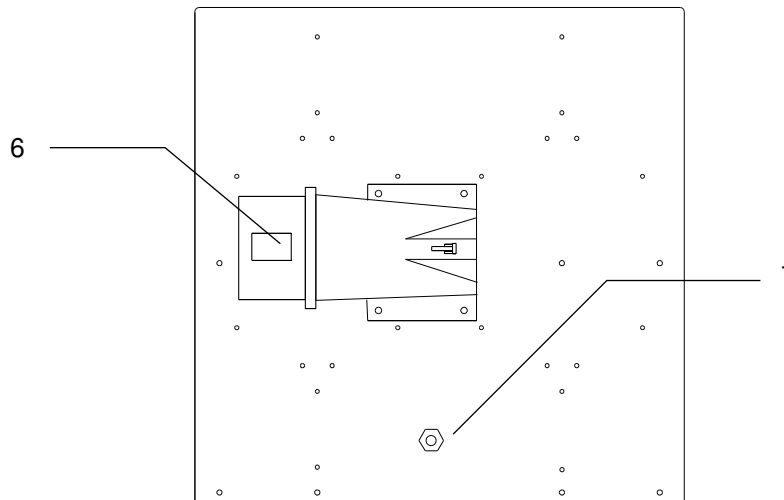

**Fig. 3-2** Rear Panel

**Legend:**

- |  |  |
|--|--|
| 1- Ground contact  | 4- RF output to EMI Signal Analyzer (50 ohm, BNC female connector) |
| 2- Mains supply to DUT   | 5- Line under test indicating led                                  |
| 3- Manual switch for phase under test (With PMM receivers the switch is disabled and the switching is automatic) | 6- Mains LISN supply   |
|  | 7- Remote PMM receiver control connector                           |

**This page has been left blank intentionally**



## 4 – PMM L3-100



### 4.1 Main specifications

Table 4-1 lists the PMM L3-100 Network performance specifications. The following conditions apply to all specifications:

- The ambient temperature must be -10° to 40°.

**TABLE 4-1 Main specifications L3-100**

<b>Frequency range:</b>	9 kHz to 30 MHz		
<b>Maximum rated output current:</b>	100 A continuous		
<b>Overload current:</b>	125 A for 5 min.		
<b>Maximum operating voltage</b>	<b>(L/PE) (N/PE):</b>	230 Vac	325 Vdc
	<b>(L/L) (L/N):</b>	400 Vac	565 Vdc
<b>AC supply frequency range:</b>	DC - 60 Hz		
<b>Equivalent circuit:</b>	50 Ohm // (5 Ohm + 50 μH)		
<b>RF output:</b>	BNC female		
<b>Test item:</b>	125 A plug and socket outlet according to IEC 309 standard		
<b>Rated temperature:</b>	-10° to + 40° C		
<b>Storage temperature:</b>	- 25° to + 75° C		
<b>Overall dimension mm (W x H x D):</b>	465 x 450 x 740		
<b>Weight:</b>	70 kg		
<b>Gross weight</b>	100 kg		

## 4.2 Front and Rear Panels

In Fig. 4-1 and Fig. 4-2 you can see front and rear connecting points and terminals of PMM L3-100 Network.

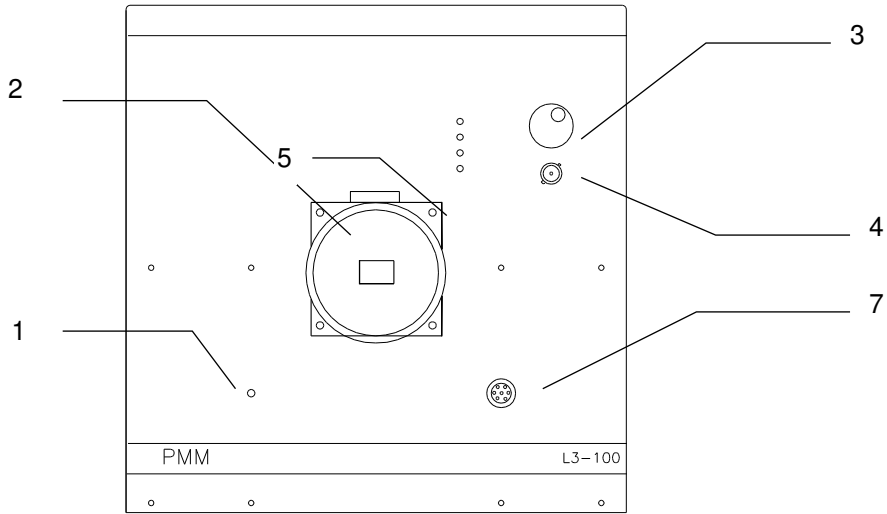

**Fig. 4-1** Front Panel

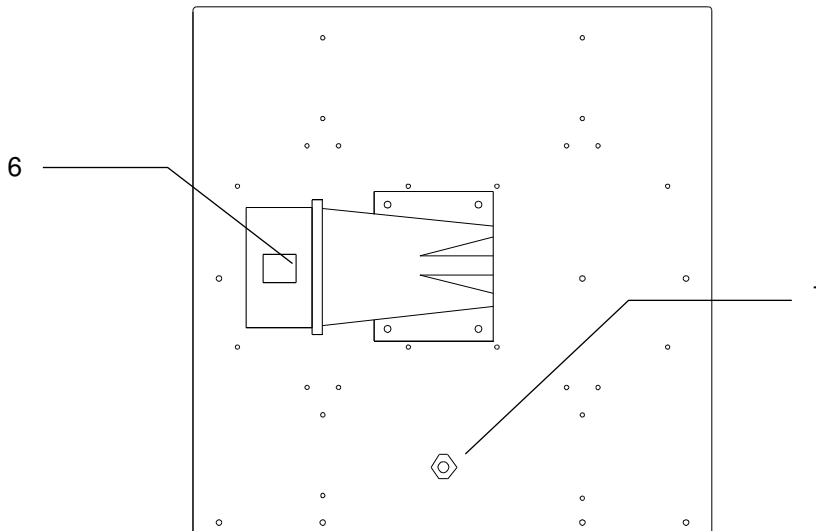

**Fig. 4-2** Rear Panel

### Legend:

- |   |  |
|---|--|
| 1- Ground contact   | 4- RF output to EMI Signal Analyzer (50 ohm, BNC female connector) |
| 2- Mains supply to DUT  | 5- Line under test indicating led                                  |
| 3- Manual switch for phase under test (With PMM receiver the switch is disabled and the switching is automatic) | 6- Mains LISN supply   |
|   | 7- Remote PMM receivers control connector                          |

## 5 – PMM L3-500 (L1-500)

### 5.1 Main specifications

The L1-500 is the 500 Ampere, single line, Line Impedance Stabilization Network (Fig. 5-2).

Four modules L1-500, inside a rack on wheels, assemble the L3-500 shown in the Fig. 5-1.

Table 5-1 lists the L1-500 and L3-500 Network performance specifications. Please read carefully and always follow all safety requirements, especially the “Safety recommendations and instructions” at pages 11 and 12 .



**Fig. 5-1** L3-500, Three-phase Artificial Mains Network, front view



**Fig. 5-2** L1-500, Single Line Artificial Mains Network, front view

**TABLE 5-1 Main specifications L3-500 (L1-500)**

<b>Frequency range:</b>	9 kHz to 30 MHz		
<b>Maximum rated output current:</b>	500 A (20 minutes, starting the test at max 25°C LISN internal temperature) 300 A (continuous)		
<b>Maximum operating voltage</b>	<b>(L/PE) (N/PE):</b>	400 Vac	565 Vdc
	<b>(L/L) (L/N):</b>	690 Vac	975 Vdc
<b>Main Power supply frequency range:</b>	DC - 60 Hz		
<b>Equivalent circuit:</b>	50 Ohm // [5 Ohm + 50 μH] with 250 μH Choke or Bypass		
<b>RF output:</b>	4 BNC female (1 for L1-500)		
<b>EUT Connector, Main Power Connector, Ground Connectors:</b>	M14 Bolts		
<b>Rated temperature:</b>	-10° to + 40° C		
<b>Storage temperature:</b>	- 25° to + 75° C		
<b>Overall dimension mm (W x H x D):</b>	555 x 930 x 830 mm (510 x 175 x 830 mm for L1-500)		
<b>Weight:</b>	248 kg (55 kg for L1-500)		
<b>Services AC Supply:</b>	230 V – 50/60 Hz – 100 VA max		
<b>Cooling Fans:</b>	2 x 120 mm		
<b>Led indications:</b>	Power, Fan, Overheating, AC Voltage Present,		
<b>Contactors:</b>	250 V AC/DC – 10 A max		

## 5.2 Front and Rear Panels

In Fig. 5-3 and Fig. 5-4 you can see front and rear connecting points and terminals of L3-500 Network.

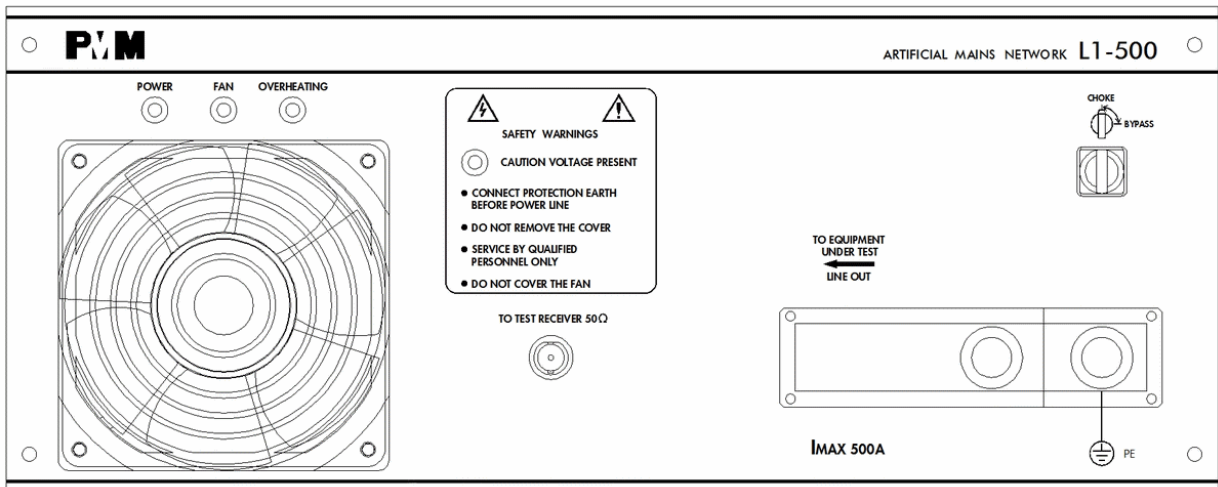

**Fig. 5-3** Front Panel

### Legend (from left to right):

- |  |  |
|--|--|
| 1- "POWER on" led .....                          | Lights up when the device is powered and switched on                               |
| 2- "FAN on" led .....                            | Lights up when the two fans are running  |
| 3- "OVERHEATING" led .....                       | Lights up to indicate the internal temperature is higher than allowed              |
| 4- FAN .....                                     | Front (pulling) FAN for internal ventilation                                       |
| 5- "CAUTION VOLTAGE PRESENT" led .....           | Lights up when the Line is connected to a 230Vac Mains.                            |
| 6- OUTPUT Connector "To Test Receiver" 50Ω ...   | BNC RF Output connector  |
| 7- Mains LINE OUT To EUT with Protective Earth . | Mains Line Output to power the Device Under Test                                   |
| 8 – CHOKE / BYPASS Selector .....                | Switch to select the 250μH coil (CHOKE position) or to bypass it (BYPASS position) |

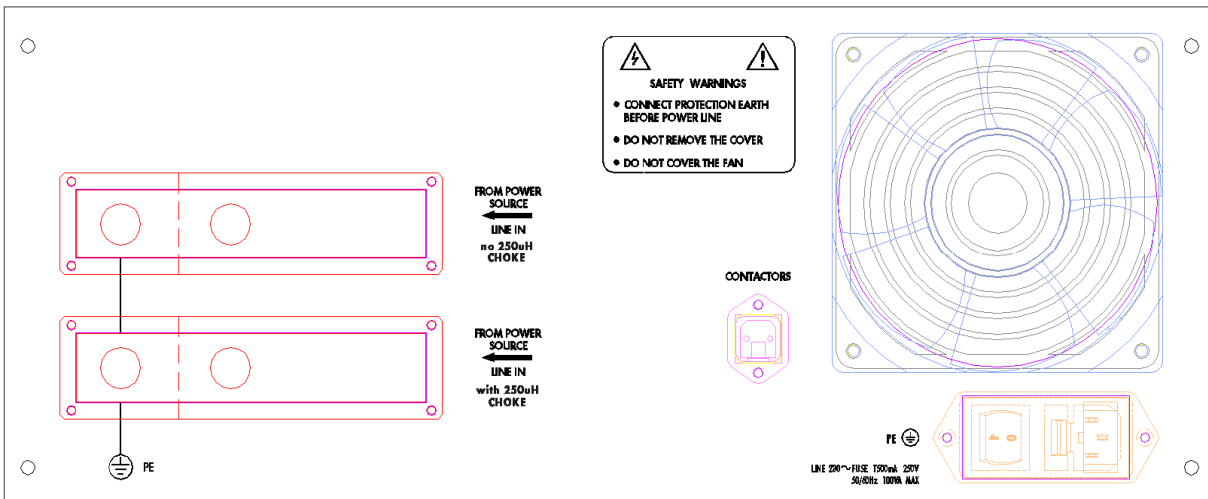

**Fig. 5-4 Rear Panel**

**Legend (from left to right):**

- |  |   |
|--|---|
| <p>1- LINE IN (no 250µH Choke),<br/>From Power source, with Protective Earth</p> <p>2- LINE IN (with 250µH Choke),<br/>From Power source, with Protective Earth</p> <p>3- Contactors .....</p> <p>4- FAN .....</p> <p>5- LINE 230V .....</p> | <p>Mains Line Input to power the Device Under Test without the 250µH series internal Choke (bypassed)</p> <p>Mains Line Input to power the Device Under Test with the 250µH series internal Choke (standard)</p> <p>Short circuited pins for Mains power enabling (open circuit when no 230V Services Supply present or when overheating fault occurs)</p> <p>Rear (pushing) FAN for internal ventilation</p> <p>Required to power all internal services including Fans, Contactors driver, Overheat protection</p> |
|--|---|

**NOTICE**

To maximize the protection against overheating it is necessary to connect all four Contactors connectors in a series like depicted in the schematic diagram on the right.

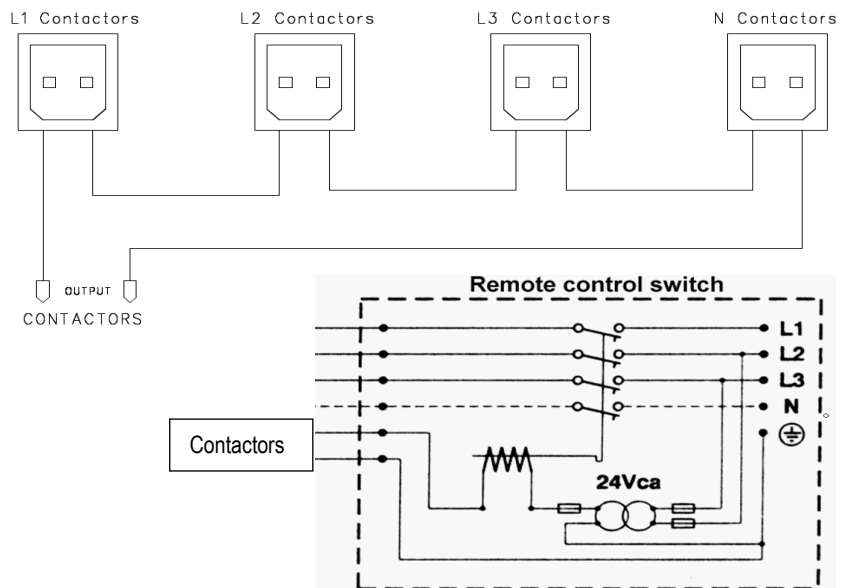

**Fig. 5-5 Contactors diagram**



To maximize the protection the four rear ground connectors must be electrically connected to each other via cables like depicted on the right.

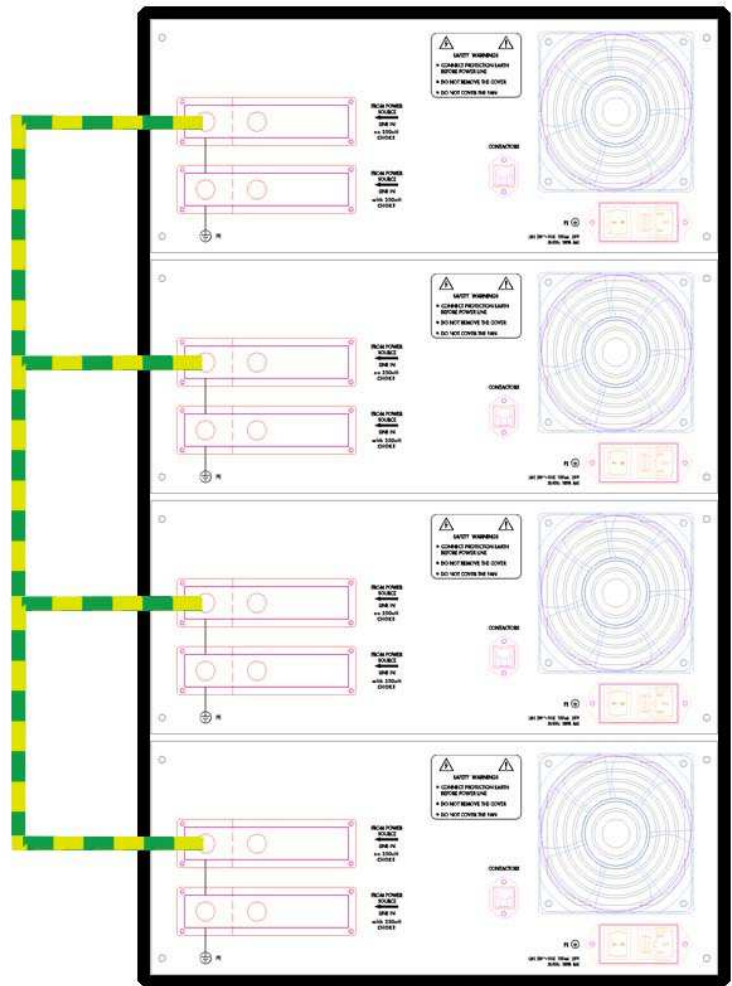

Fig. 5-6 Four rear ground connectors connection

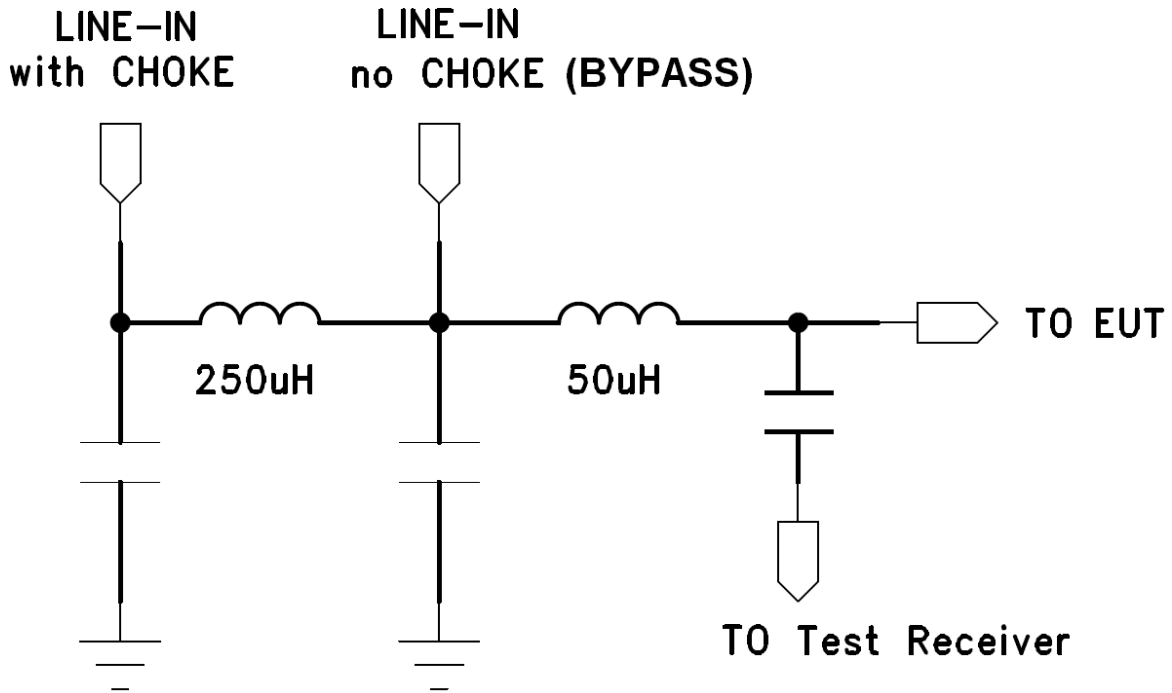

Fig. 5-7 L1-500 (same as each L3-500 line) equivalent circuit



## 6 - Installation

---

### 6.1 Introduction

This section provides the information needed to install the PMM LISN Network.

### 6.2 Initial inspection

Included is information pertinent to initial inspection, power requirements, interconnections, environment, instrument mounting, cleaning, storage and shipment.



**To avoid hazardous electrical shock, do not turn on the instrument when there are signs of shipping damage to any portion of it.**

### 6.3 Packing Unpacking

Inspect the shipping container for damage.

If the shipping container or cushion material is damaged, it should be kept until the contents of the shipment have been checked for completeness and the instrument has been checked mechanically and electrically.

Verify the accessories availability in the shipping container referring to the accessories check list enclosed with the Operating Manual.

Notify any damage to the carrier as well as the NARDA Representative.

To remove the LISN, open the wooden box and unscrew the four screws that hold the LISN at the bottom side of the palette.



**Unit weight exceed 80 kg. To avoid hazard of personal injury use a suitable lifting device for PMM L3-100 Network handling.**



**Unit weight exceed 200 kg. To avoid hazard of personal injury use a suitable lifting device for PMM L3-500 Network handling.**



**Unit weight exceed 50 kg. To avoid hazard of personal injury use a suitable lifting device for PMM L3-64, PMM L3-64/690 and PMM L1-500 Network handling.**

#### 6.4 Preparation for use

From the mains lines conductor to the case of the unit there is a high leakage current.

The mains lines conductor is connected to ground via high value capacitors due to the measurement system to be applied.



**Over current protection is not provided in the LISN. The LISN must be connected to a power mains which has the properly rated mains protection installed.**



The leakage currents between the phases and the earth line generally exceed permitted limits for typical environments due to internal capacitors; for this reason it is mandatory to use a current rated insulating transformer to supply the PMM LISN Network.



**PMM LISN Network, the insulating transformer and Equipment Under Test must be provided by an appropriate current rated contact breaker or fuses as closest as possible on the supply line and with a safety indication of equipment operated by.**

#### 6.5 Pilot circuit

According to EN 60309 (IEC 309) Normative, the industrial mains plugs and outlets, with an operating current, are provided with an auxiliary connector called Pilot Circuit contact.

The Pilot Circuit contact is used to avoid mains plug disconnection with an operating high current load connected. In this case a current rated remote control switch shall be provided to allow a safe automatic mains disconnection.



The Pilot Circuit contact and the remote control switch, connected according to the following figure example, also allows to check automatically the protection earth conductor continuity till the Device Under Test mains connection.

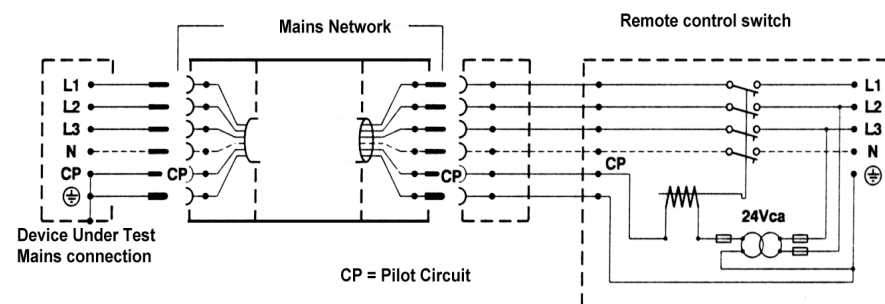

Fig. 6-1 Pilot Circuit connection example

This is a Safety Class I equipment, it is provided with a protective earth terminal. Before connecting this instrument, ensure that an uninterruptible safety earth ground is provided from the main power source to the product protective earth connection. If this instrument is to be connected to other equipment or accessories, prior to energizing either unit verify that a common ground exists between them. Any interruption or loosening of the protective earth ground conductor, either inside or outside the unit or in an extension cable will cause a potential shock hazard that could result in personal injury. Verify the safety earth ground functionality before operation.



**6.6 Installation Check list** Before operation ensure the following steps are taken:

- Check the line voltage to ensure the compatibility with the equipment requirements.
- Ensure that the to be provided fuse or breaker current rating is appropriate for the equipment setup.
- Protection earth line is connected to mains supply input on the rear panel.
- Ensure that cables and terminals used to connect PMM LISN Network to supply line and to Equipment Under Test are suitable for the setup current rating and proper safety insulation.
- Verify that 50 ohm RF cable to the EMI Signal Analyzer input be disconnected before switch on or off the supply line.
- Prior to energizing either unit verify that a common ground connection exists between all equipment in the test setup and safety protection earth.

**NOTICE**

**To allow correct equipment ventilation ensure that the vent grid on the equipment covers be free by any obstructing object.**

**This page has been left blank intentionally**

## **7 - Operating PMM Networks**

---

### **7.1 Operating PMM Networks**

To operate the PMM Artificial Mains Networks connect the IEC plug on the rear input to the mains insulating transformer.

To avoid any damage caused by transient current pulses, connect the RF cable to the receiver only after the AC supply has been switched on.

The Equipment Under Test should be connected to the D.U.T. connector.

To select the phase line to be tested operate the phase knob on the front panel, in this case there is no led indication.

Using PMM receivers the phase switching can be automatically performed; in this case the phase under test will be indicated by the led in the front panel.

#### **NOTICE**

**To avoid any damage caused by transient current pulses, disconnect the test Signal Analyzer input before switching AC supply on or off**

#### **NOTICE**

**To allow correct equipment ventilation ensure that all the vent grids on the equipment covers be free by any obstructing object.**

**The PMM LISN continuous operation at higher current limit shall not exceed one hour, a rest period of at least a half hour shall be observed to allow the equipment to cool down.**

## 7.2 Test Set-Up Considerations

Measurement repeatability is the main concern of standards and regulations, that exactly define the test set-up for interference measurements. The Artificial Mains Network complies with CISPR publ.16 (part 2), VDE 0876 and the American FCC part 15 rules and regulations.

The test SET-UPS required for various standards are largely identical; a detailed description is given in VDE 0877 part 1. (par. 9.2 "Measurements using LISNs").

The DUT has to be positioned on a non-metallic or conductive table (height >80cm.), 40 cm. in front of a metallic grounded wall with dimensions of at least 2 m. x 2 m.

The table may also be used inside a screened room.

The distance of the DUT from any metallic part may affect the measured RFI voltage values; VDE 0877 exactly define the dimensions for the test configurations, by means of the following drawing:

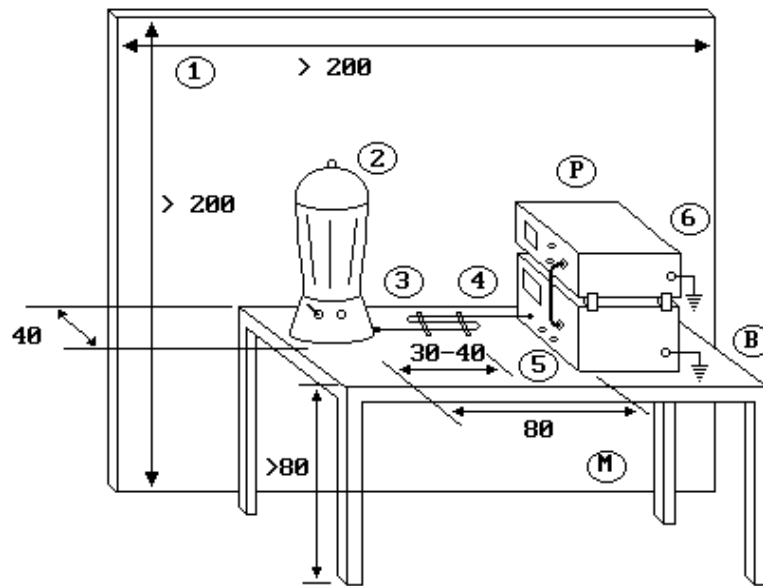

**Fig. 7-1** Typical test set-up

The figure 7-1 describes the test configuration and the interconnection of a mains operated DUT, according to the above mentioned VDE specification, where:

1. Metallic grounded wall;
2. Device Under Test (DUT);
3. Folded mains cable fixed with strips of adhesive tape;
4. Non-metallic table;
5. RFI measuring receiver;
6. Line Impedance Stabilization Network (LISN) with:
  - B - connection to reference ground.
  - P - jack for DUT.
  - M - coaxial connection to measuring receiver.

All dimensions are given in centimeters.

**Internal hardware checks and repairs shall be performed only by NARDA authorized assistance and service centers.**

**The manufacturer, the worldwide distributors and the national distributors shall not be responsible and kept liable for damages to goods, to instruments or persons caused during unauthorized operations on the instrument, or by manumitted instrument.**

**NOTICE**

### 7.3 Network verification and maintenance

To verify proper operation of the PMM Networks use the following test procedure:

#### **NOTICE**

**Do not connect any AC or DC supply to PMM Networks during this verification test.**

Test equipment needed:

1. RF Generator and level measuring calibrated instrument or
2. Spectrum Analyzer with Tracking Generator.

In both cases, instrument shall be working at 1 MHz.

Verification test procedure:

1. Connect the RF signal (or tracking signal) to the mains output of L3-100 making sure that the ground is connected to the shield of the RF cable (grounded). The RF signal (or tracking signal) shall be taken to L1 and L2 sockets, alternatively
2. Connect PMM Networks RF output 3 to the level-meter input (or Spectrum Analyzer input).
3. Attenuation between generated signal level and measured level on output shall be less than 0.5dB at 1 MHz. If higher than 0.5 dB, please refer to qualified NARDA Service Center for maintenance of the unit.

**7.4 Remote receiver control connector**

The Remote receiver control connector is on the rear panel.

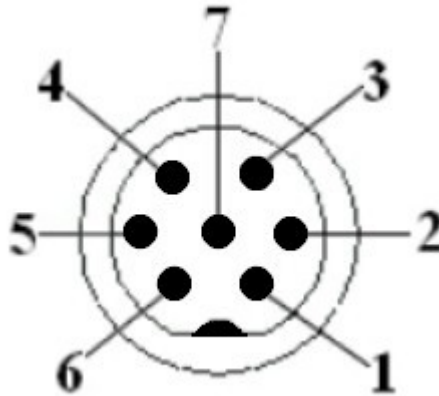

**Fig. 7-2** "Remote Control" connector (Front view)

**Legend:**

- 1 = (GND)
- 2 = (+12V)
- 6 = (TTL1)
- 7 = (TTL2)

TTL1	TTL2	LINE
0	0	N
0	1	L2
1	0	L1
1	1	L3

**Legend:**

- 0 → GND
- 1 → +5V



**7.5 LISN remote cable Configuration for PMM 9010F**

The following figure shows the LISN remote cable pin configuration. The cable is provided with the LISNs.

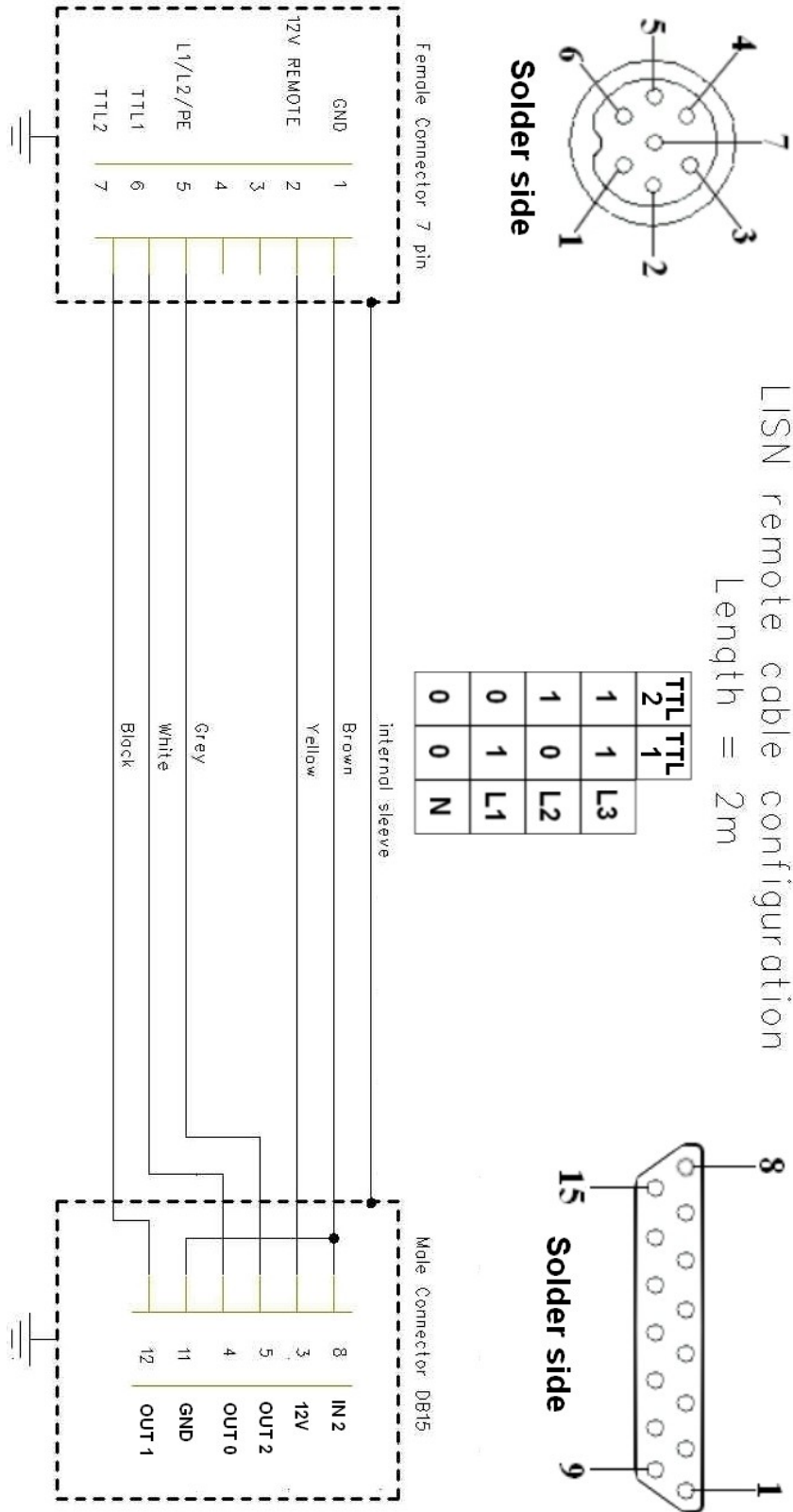
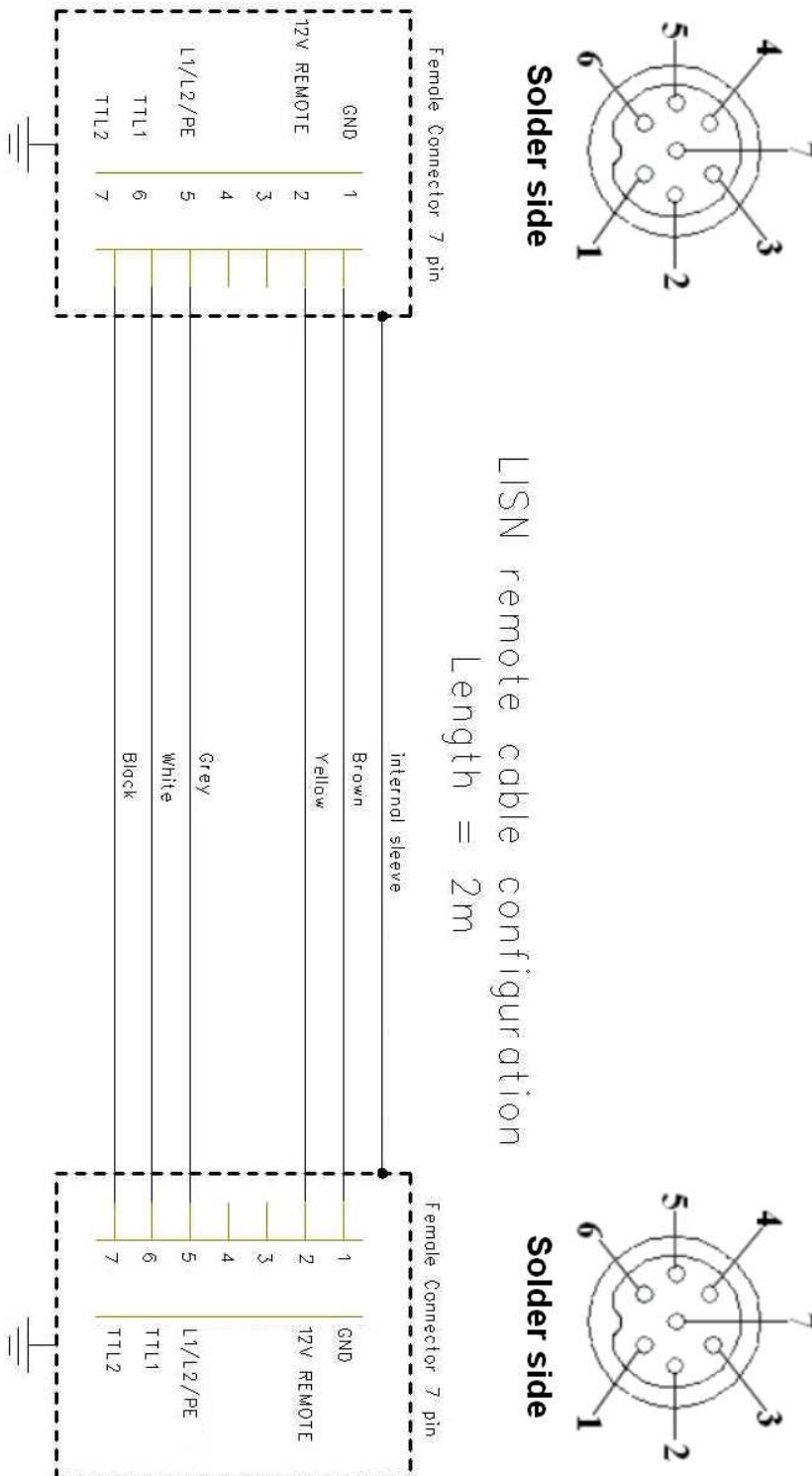

**Fig. 7-3** LISN remote cable configuration for PMM 9010F

**7.6 LISN remote cable Configuration for PMM 8010**

The following figure shows the LISN remote cable pin configuration. The cable can be requested to Narda or you can make it by yourself.

**The PMM 8010 is no longer supported. Please, check the manufacturing status of the Narda products from the website at <http://www.narda-sts.it> or contact your Narda – PMM local Dealer**



**Fig. 7-4 LISN remote cable configuration for PMM 8010**

## 8 - Accessories

### 8.1

### ***PMM SBRF4 RF Switching Box (optional)***

#### **Introduction**

PMM SBRF4 RF Switching Box is a versatile Accessory designed to operate the RF 300 Large Loop Antenna and the PMM Artificial Mains Networks (LISN) by the PMM EMI Receivers.

The PMM SBRF4 RF Switching Box can be used to connect sources that have multiple outputs (up to 4) like the PMM L3-500 LISN model or multiple L1-150s, LLAs, and also LISNs, antennas and transducers by other manufactures to any receiver that has one input only.

The SBRF4 allows to switch manually or automatically (when driving a PMM EMI Receiver by a PC running the proper PMM software) between the lines.

The PMM SBRF4 can be used to switch the outputs of any single-line transducers (Antennas, LISNs, probes) to measure RF emissions.



**Fig. 8-1** PMM SBRF4 RF Switching Box

**Specifications** The following conditions apply to all specifications:

- Ambient temperature between -10°C and 50°C

**TABLE 8-1 Technical Specifications of SBRF4**

<b>Frequency range</b>	Up to 108 MHz
<b>Max input level</b>	+27 dBm
<b>Insertion loss</b>	0.75 dB @ 108 MHz Typical without High Pass Filter
<b>Compatibility</b>	with all Artificial Mains Networks and Large Loop Antennas.
<b>Supply</b>	from Remote Control Input (10-15 Vdc 100 mA max.)
<b>RF Output</b>	50 Ω, BNC female
<b>RF Input</b>	50 Ω, BNC female
<b>Remote Control</b>	Remote control connector for PMM EMI Receivers
<b>Functions</b>	Manual or automatic switch for phase/axis under test Remote control from PMM EMI Receivers Band switch Selectable 50Ω termination Selectable 150 kHz High Pass Filter
<b>Operating temperature</b>	-10°C to +50°C
<b>Storage temperature</b>	-20°C to +70°C
<b>Size (W x H x D)</b>	80 x 41.5 x 250 mm
<b>Weight</b>	950 g

**Instrument Items** PMM SBRF4 includes the following items:

- PMM SBRF4 RF Switching Box
- n°5 RF Cables
- LISN Control Cable for 9010F
- Software Media including user's manual.
- Certificate of compliance

**Other accessories** PMM SBRF4 can be used with other accessories available on the market, like:

- PMM LISNs
- Antennas and Loops;
- Near Field Probes;
- RF300 Large Loop Antenna

**Housing**

The PMM SBRF4 is built in a metallic housing; on the front side are located the 50Ω Loaded switch, the band Switch, the manual switch for Line/Axis and LEDs; on the right side the Remote control and the RF output for EMI Receivers; on the left side the RF input for lines/axis under test.

**Front view**

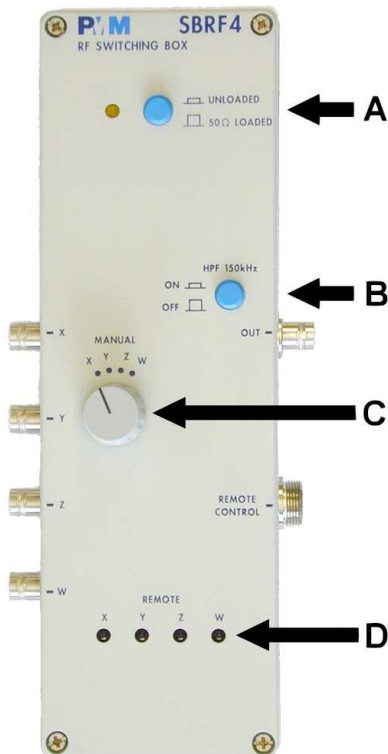

**Fig. 8-2** Front view

A – Selectable open or 50Ω termination unselected inputs

B - Filter 150kHz-108MHz

C - Manual switch for phase/axis under test (with PMM receivers the switch is disabled and the switching is automatic)

D – LED showing the line under test

**Right view**

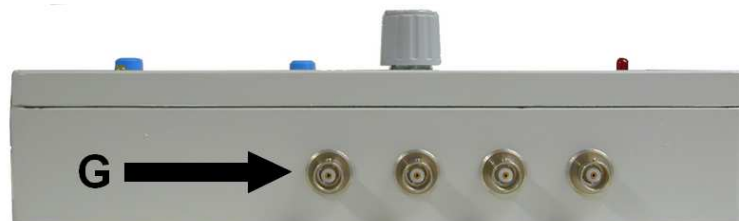

**Fig. 8-3** Right view

E - Remote control connector for PMM 9010F or PMM 9010/30P

F – RF output to EMI Receiver

**Left view**

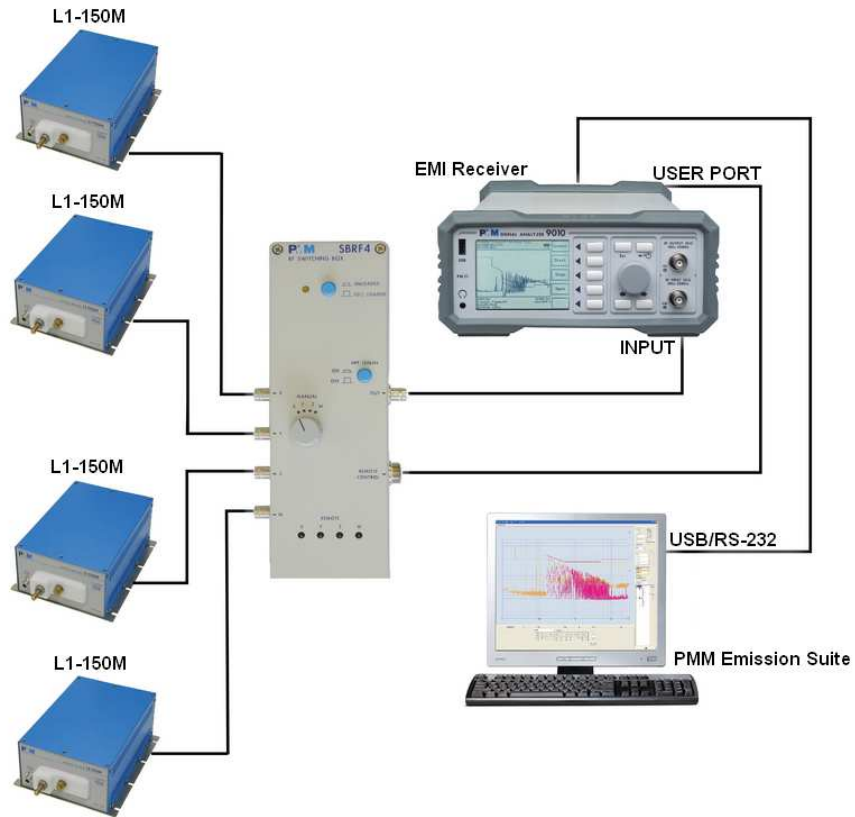

**Fig. 8-4** Left view

G – RF input for lines/axis under test

**System configuration**

The PMM SBRF4 RF Switching Box can operate in combination with external Artificial Mains Network or Large Loop Antenna. Some examples of connections are illustrated in the following figures:



**Fig. 8-5** PMM SBRF4 with external Artificial Mains Network

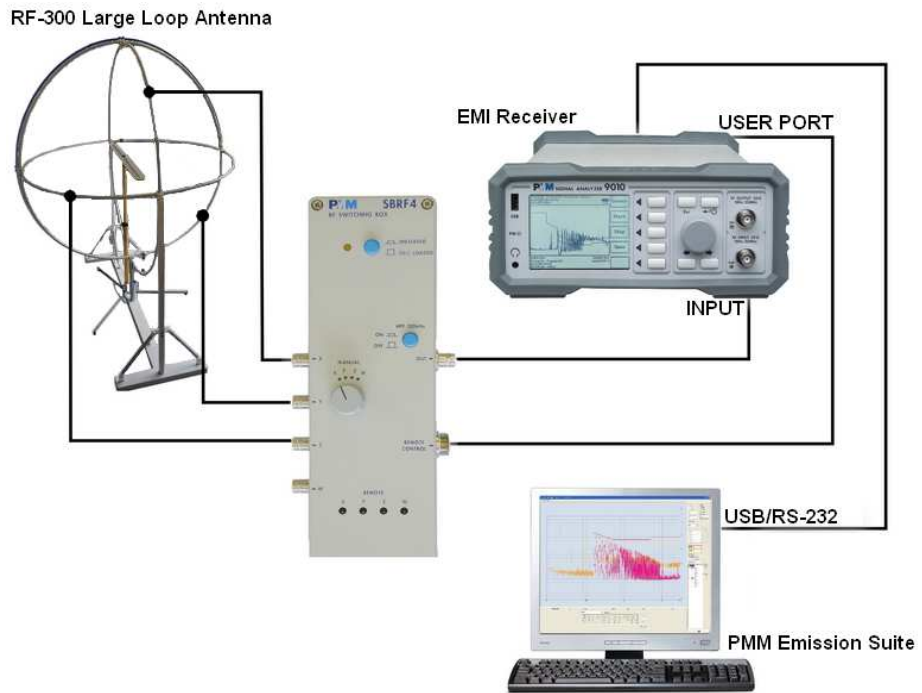

**Fig. 8-6** PMM SBRF4 with RF300 Large Loop Antenna

## Installation and use

**PMM SBRF4 with generic Artificial Mains Network** Following the instructions below to install and use the PMM SBRF4 with generic Artificial Mains Networks (LISN):

- Position the LISNs where required, with proper grounding and mechanical stability;
- Connect the LISNs RF output(s) to the SBRF4 RF input(s);
- Connect the SBRF4 RF output to the PMM 9010F or 9010/30P Receiver RF input; use the manual switch for switching the LISNs;
- Connect the Remote control connector of the SBRF4 and the User Port of the Receiver by the special cable supplied with the SBRF4 to automatically control the Lines via the PMM Emission Suite Software.



- The button “B” (Fig. 1.2) enables the 150kHz high pass filter to the RF output.



- The button “A” (Fig. 1.2) is used to terminate the non selected inputs on 50  $\Omega$ . For further information see CISPR16-1-2.

**PMM SBRF4 with  
RF300 Large Loop  
Antenna**

Follow the instructions below to install and use the PMM SBRF4 with an RF300 Large Loop Antenna:

- Establish an appropriate area to erect the RF300 making sure it is leveled to ensure stability; the details of the assembly are included in the RF300's manual;
- Connect the three axis of the RF300 to the RF input of the SBRF4 in the order X, Y, Z;
- Connect the RF output of the SBRF4 to the RF input of the PMM 9010F or 9010/30P Receiver; use the manual switch for switching the axis under test;
- Connect the Remote control connector of the SBRF4 and the User Port of the Receiver by the special cable supplied with the SBRF4 to automatically control the Loop Antenna axis via the PMM Emission Suite Software.



- The button "B" (Fig. 1.2) enables the 150kHz high pass filter to the RF output; it must be always off for this application.



- The button "A" (Fig. 1.2) is used to terminate the non selected inputs on open circuit.



**Caro cliente**

grazie per aver acquistato un prodotto NARDA! Sei in possesso di uno strumento che per molti anni ti garantirà un'alta qualità di servizio. NARDA riconosce l'importanza del Cliente come ragione di esistenza; ciascun commento e suggerimento, sottoposto all'attenzione della nostra organizzazione, è tenuto in grande considerazione. La nostra qualità è alla ricerca del miglioramento continuo. Se uno dei Suoi strumenti NARDA necessita di riparazione o calibrazione, può aiutarci a servirla più efficacemente compilando questa scheda e accludendola all'apparecchio.

Tuttavia, anche questo prodotto diventerà obsoleto. In questo caso, ti ricordiamo che lo smaltimento dell'apparecchiatura deve essere fatto in conformità con i regolamenti locali. Questo prodotto è conforme alle direttive WEEE dell'Unione Europea (2002/96/EC) ed appartiene alla categoria 9 (strumenti di controllo). Lo smaltimento, in un ambiente adeguato, può avvenire anche attraverso la restituzione del prodotto alla NARDA senza sostenere alcuna spesa. Può ottenere ulteriori informazioni contattando i venditori NARDA o visitando il nostro sito Web [www.narda-sts.it](http://www.narda-sts.it).

**Dear Customer**

thank you for purchasing a NARDA product! You now own a high-quality instrument that will give you many years of reliable service. NARDA recognizes the importance of the Customer as reason of existence; in this view, any comment and suggestion you would like to submit to the attention of our service organization is kept in great consideration. Moreover, we are continuously improving our quality, but we know this is a never ending process. We would be glad if our present efforts are pleasing you. Should one of your pieces of NARDA equipment need servicing you can help us serve you more effectively filling out this card and enclosing it with the product.

Nevertheless, even this product will become obsolete. When that time comes, please remember that electronic equipment must be disposed of in accordance with local regulations. This product conforms to the WEEE Directive of the European Union (2002/96/EC) and belongs to Category 9 (Monitoring and Control Instruments). You can return the instrument to us free of charge for proper environment friendly disposal. You can obtain further information from your local NARDA Sales Partner or by visiting our website at [www.narda-sts.it](http://www.narda-sts.it).

**Servizio richiesto:**  *Service needed:*

Solo taratura     Riparazione     Riparazione & Taratura     Taratura SIT     Altro:  
 Calibration only     Repair     Repair & Calibration     Certified Calibration     Other:

**Ditta:**

*Company:*

**Indirizzo:**

*Address:*

**Persona da contattare:**

*Technical contact person:*

**Telefono:**

*Phone n.*

**Modello:**

*Equipment model:*

**Numero di serie:**

*Serial n.*

**Accessori ritornati con l'apparecchiatura:**  Nessuno     Cavo(i)     Cavo di alimentazione     Altro:  
 Accessories returned with unit:     None     Cable(s)     Power cable     Other:

**Sintomi o problemi osservati:**  *Observed symptoms / problems:*

**Guasto:**  Fisso     Intermittente    **Sensibile a :**  Freddo     Caldo     Vibrazioni     Altro  
 Failure:  Continuous     Intermittent    **Sensitive to:**  Cold     Heat     Vibration     Other

**Descrizione del guasto/condizioni di funzionamento:**

*Failure symptoms/special control settings description:*

---

---

---

---

---

---

---

---

**Se l'unità è parte di un sistema descriverne la configurazione:**

*If unit is part of system please list other interconnected equipment and system set up:*

---

---

---

---

---

---

---

---

