

---

# User's Manual

## PMM RA-01

## PMM RA-01-HV

### ACTIVE ROD ANTENNA

#### **SERIAL NUMBER OF THE INSTRUMENT**

You can find the Serial Number in a side of the box.

Serial Number is in the form: 0000X00000.

The first four digits and the letter are the Serial Number prefix, the last five digits are the Serial Number suffix. The prefix is the same for identical instruments, it changes only when a configuration change is made to the instrument.

The suffix is different for each instrument.

**NOTE:**

® Names and Logo are registered trademarks of Narda Safety Test Solutions GmbH – Trade names are trademarks of the owners.



If the instrument is used in any other way than as described in this User's Manual, it may become unsafe.

Before using this product, the related documentation must be read with great care and fully understood to familiarize with all the safety prescriptions.

To ensure the correct use and the maximum safety level, the User shall know all the instructions and recommendations contained in this document.



This product is a **Safety Class I** instrument according to IEC classification and has been designed to meet the requirements of EN61010-1 (Safety Requirements for Electrical Equipment for Measurement, Control and Laboratory Use).

In accordance with the IEC classification, the power supply of this product meets requirements **Safety Class III** and **Installation Category II** (having double insulation and able to carry out mono-phase power supply operations).

It complies with the requirements of **Pollution Class II** (usually only non-conductive pollution). However, occasionally it may become temporarily conductive due to condense on it.

The information contained in this document is subject to change without notice.

**KEY TO THE ELECTRIC AND SAFETY SYMBOLS:**



You now own a high-quality instrument that will give you many years of reliable service. Nevertheless, even this product will eventually become obsolete. When that time comes, please remember that electronic equipment must be disposed of in accordance with local regulations. This product conforms to the WEEE Directive of the European Union (2002/96/EC) and belongs to Category 9 (Monitoring and Control Instruments). You can return the instrument to us free of charge for proper environment friendly disposal. You can obtain further information from your local NARDA Sales Partner or by visiting our website at [www.narda-sts.it](http://www.narda-sts.it).



Warning, danger of electric shock



Earth



Read carefully the Operating Manual and its instructions, pay attention to the safety symbols.



Unit Earth Connection



Earth Protection



Equipotential

**KEY TO THE SYMBOLS USED IN THIS DOCUMENT:**



The DANGER sign draws attention to a serious risk to a person's safety, which, if not avoided, will result in death or serious injury. All the precautions must be fully understood and applied before proceeding.



The WARNING sign indicates a hazardous situation, which, if not avoided, could result in death or serious injury. All the precautions must be fully understood and applied before proceeding.



The CAUTION sign indicates a hazardous situation, which, if not avoided, could result in minor or moderate injury.



The NOTICE sign draws attention to a potential risk of damage to the apparatus or loss of data.



The NOTE sign draws attention to important information.



Note and symbols

# Contents

|   |                  |
|---|------------------|
| <b>Safety recommendations and instructions.....</b>   | <b>Page</b><br>V |
| <b>RA-01 EC Declaration of Conformity .....</b>       | VI               |
| <b>RA-01-MIL EC Declaration of Conformity .....</b>   | VII              |
| <b>RA-01-HV EC Declaration of Conformity .....</b>    | VIII             |
| <br>  |                  |
| <b>1 General Information</b>                          | <b>Page</b>      |
| 1.1 Documentation.....                                | 1-1              |
| 1.2 Introduction to the PMM RA-01.....                | 1-2              |
| 1.3 Calibration of the PMM RA-01.....                 | 1-2              |
| 1.4 Instrument Items.....                             | 1-2              |
| 1.5 Optional accessories.....                         | 1-2              |
| 1.6 Main specifications.....                          | 1-3              |
| 1.7 Main Features.....                                | 1-3              |
| 1.8 PMM RA-01 parts.....                              | 1-4              |
| <br>  |                  |
| <b>2 Mounting Instructions</b>                        | <b>Page</b>      |
| 2.1 Introduction.....                                 | 2-1              |
| 2.2 Initial inspection.....                           | 2-1              |
| 2.3 Environment.....                                  | 2-1              |
| 2.4 Return for service.....                           | 2-1              |
| 2.5 Equipment cleaning.....                           | 2-1              |
| 2.6 PMM RA-01 mounting instructions.....              | 2-2              |
| <br>  |                  |
| <b>3 Using PMM RA-01</b>                              | <b>Page</b>      |
| 3.1 How it works.....                                 | 3-1              |
| 3.2 Power Switch.....                                 | 3-1              |
| 3.3 Battery Charging.....                             | 3-1              |
| 3.4 ESD Risks.....                                    | 3-1              |
| 3.5 Principles of operation.....                      | 3-1              |
| 3.6 Antenna Factor.....                               | 3-2              |
| 3.7 Procedure of calibration.....                     | 3-2              |
| <br>  |                  |
| <b>4 Accessories</b>                                  | <b>Page</b>      |
| 4.1 Introduction .....                                | 4-1              |
| 4.2 Preliminary inspection .....                      | 4-1              |
| 4.3 Work environment .....                            | 4-1              |
| 4.4 Return for repair .....                           | 4-1              |
| 4.5 Cleaning .....                                    | 4-1              |
| 4.6 PMM TR-01A Set (optional).....                    | 4-2              |
| 4.6.1 TR-01A Set .....                                | 4-2              |
| 4.6.2 RA-01 installation on TR-01A Wooden tripod..... | 4-4              |

## Figures

---

| Figure |                                   | Page |
|--------|-----------------------------------|------|
| 1-1    | PMM RA-01 Active Rod Antenna..... | 1-1  |
| 1-2    | PMM RA-01 parts.....              | 1-4  |
| 1-3    | PMM RA-01 front view .....        | 1-4  |
| 4-1    | PMM TR01 Wooden Tripod.....       | 4-2  |
| 4-2    | Adjustable joint .....            | 4-2  |
| 4-3    | Column strengthener.....          | 4-3  |
| 4-4    | Soft carrying case.....           | 4-3  |
| 4-5    | RA-01 parts and assembly.....     | 4-4  |

## Tables

---

| Table |   | Page |
|-------|---|------|
| 1-1   | Technical Specification.....                | 1-3  |
| 1-2   | Main features.....                          | 1-3  |
| 4-1   | PMM TR-01 Wooden tripod with extension..... | 4-2  |
| 4-2   | Column strengthener Specifications.....     | 4-3  |
| 4-3   | Soft carrying case.....                     | 4-3  |

** WARNING **SAFETY RECOMMENDATIONS AND INSTRUCTIONS****

This product has been designed, produced and tested in Italy, and it left the factory in conditions fully complying with the current safety standards. To maintain it in safe conditions and ensure correct use, these general instructions must be fully understood and applied before the product is used.

- When the device must be connected permanently, first provide effective grounding;
- If the device must be connected to other equipment or accessories, make sure they are all safely grounded;
- In case of devices permanently connected to the power supply, and lacking any fuses or other devices of mains protection, the power line must be equipped with adequate protection commensurate to the consumption of all the devices connected to it;
- In case of connection of the device to the power mains, make sure before connection that the voltage selected on the voltage switch and the fuses are adequate for the voltage of the actual mains;
- Devices in Safety Class I, equipped with connection to the power mains by means of cord and plug, can only be plugged into a socket equipped with a ground wire;
- Any interruption or loosening of the ground wire or of a connecting power cable, inside or outside the device, will cause a potential risk for the safety of the personnel;
- Ground connections must not be interrupted intentionally;
- To prevent the possible danger of electrocution, do not remove any covers, panels or guards installed on the device, and refer only to NARDA Service Centers if maintenance should be necessary;
- To maintain adequate protection from fire hazards, replace fuses only with others of the same type and rating;
- Follow the safety regulations and any additional instructions in this manual to prevent accidents and damages.

# Dichiarazione di Conformità *EC Declaration of Conformity*

In accordo alla Decisione 768/2008/EC, conforme alle direttive EMC 2014/30/UE, Bassa Tensione 2014/35/UE e RoHS 2011/65/UE, ed anche alle norme ISO/IEC 17050-1 e 17050-2.

*In accordance with the Decision 768/2008/EC, compliant to the Directives EMC 2014/30/UE, Low Voltage 2014/35/UE and RoHS 2011/65/EU, also compliant to the ISO/IEC standard 17050-1 and 17050-2*

Il costruttore  
*The manufacturer* **narda Safety Test Solutions S.r.l. Socio Unico**

Indirizzo  
*Address* **Via Benessea, 29 / B**

**I-17035 Cisano sul Neva (SV) - Italy**

**sulla base delle seguenti norme europee armonizzate, applicate con esito positivo:**  
***based on the following harmonized European Standards, successfully applied:***

EMC - Emissioni:  
*EMC - Emission:* **EN 61326-1 (2013)**

EMC - Immunità:  
*EMC - Immunity:* **EN 61326-1 (2013)**

Sicurezza:  
*Safety:* **CEI EN 61010-1 (2010)**

**dichiara, sotto la propria responsabilità, che il prodotto:**  
***declares, under its sole responsibility, that the product:***

Descrizione  
*Description* **ROD ANTENNA SYSTEM**

Modello  
*Model* **PMM RA-01**

**è conforme ai requisiti essenziali delle seguenti Direttive:**  
***conforms with the essential requirements of the following Directives:***

Bassa Tensione  
*Low Voltage* **2014/35/EU**

Compatibilità Elettromagnetica  
*EMC* **2014/30/EU**

RoHS  
*RoHS* **2011/65/EU**

**Cisano sul Neva, 03 May 2017**

**Egon Stocca**  
**General Manager**



# Dichiarazione di Conformità *EC Declaration of Conformity*



In accordo alla Decisione 768/2008/EC, conforme alle direttive EMC 2014/30/UE, Bassa Tensione 2014/35/UE e RoHS 2011/65/UE, ed anche alle norme ISO/IEC 17050-1 e 17050-2.

*In accordance with the Decision 768/2008/EC, compliant to the Directives EMC 2014/30/UE, Low Voltage 2014/35/UE and RoHS 2011/65/EU, also compliant to the ISO/IEC standard 17050-1 and 17050-2*

Il costruttore  
*The manufacturer*

**narda Safety Test Solutions S.r.l. Socio Unico**

Indirizzo  
*Address*

**Via Benessea, 29 / B**

**I-17035 Cisano sul Neva (SV) - Italy**

**sulla base delle seguenti norme europee armonizzate, applicate con esito positivo:**  
***based on the following harmonized European Standards, successfully applied:***

EMC - Emissioni:  
*EMC - Emission:*

**EN 61326-1 (2013)**

EMC - Immunità:  
*EMC - Immunity:*

**EN 61326-1 (2013)**

Sicurezza:  
*Safety:*

**CEI EN 61010-1 (2010)**

**dichiara, sotto la propria responsabilità, che il prodotto:**  
***declares, under its sole responsibility, that the product:***

Descrizione  
*Description*

**ROD ANTENNA SYSTEM**

Modello  
*Model*

**PMM RA-01-HV**

**è conforme ai requisiti essenziali delle seguenti Direttive:**  
***conforms with the essential requirements of the following Directives:***

Bassa Tensione  
*Low Voltage*

**2014/35/EU**

Compatibilità Elettromagnetica  
*EMC*

**2014/30/EU**

RoHS  
*RoHS*

**2011/65/EU**

**Cisano sul Neva, 03 May 2017**

**Egon Stocca**

**General Manager**

**This page has been left blank intentionally**



## **1 – General Information**

---



**Fig. 1-1** PMM RA-01 Active Rod Antenna

### **1.1 Documentation**

Enclosed with this manual are:

- a service questionnaire to send back to NARDA in case an equipment service is needed.
- an accessories checklist to verify all accessories enclosed in the packaging.

**1.2 Introduction to the PMM RA-01 Active Rod Antenna**

The PMM RA-01 is designed to provide a good solution to measure low level fields from 9 kHz to 30 MHz (RA-01) and 150kHz to 30MHz (RA-01-HV).

RA-01 can be used in conjunction with any PMM Receiver or Spectrum Analyzer, although its ideal companion for on-site measurements is the EMI Receiver Unit 9010F, portable and fully compliant with CISPR-16-1-1.

**1.3 Calibration of the PMM RA-01 Active Rod Antenna**

Each antenna is individually calibrated. By knowing the actual antenna factors and performance characteristics of an antenna instead of typical data, you can more accurately calculate the field strength in your tests. Annual recalibration is recommended for rod antennas.

**1.4 Instrument Items**

The Active Rod Antenna includes the following:

- PMM RA-01 box or RA-01-HV box
- PMM RA-01 monopole
- Antenna Base plate
- AC/DC Converter with plug adapters
- Carrying Case
- Antenna certificate
- User's manual

**1.5 Optional accessories**

PMM RA-01 can be used with several optional accessories, the most common being the following:

- TR-01A set (TR01 60-180 cm wooden column extendable tripod, column strengthener, soft carrying case).

## 1.6 Main Specifications

Table 1-1 lists the PMM RA-01 performance specifications.

The following conditions apply to all specifications:

- The ambient temperature shall be -10°C to 60°C

**TABLE 1-1 Technical specification**

|   |  |         |
|---|--|---------|
| <b>Frequency range</b>                    | 9 kHz – 30 MHz (RA-01)<br>150kHz – 30 MHz (RA-01-HV) |         |
| <b>Output Impedance</b>                   | 50Ω  |         |
| <b>Output connector</b>                   | BNC female   |         |
| <b>Internal Battery</b>                   | Ni-MH Rechargeable 7,2 V - 720 mAh                   |         |
| <b>Operating time</b>                     | > 24 hours   |         |
| <b>Recharging time</b>                    | 6 hours  |         |
| <b>Tripod mounting</b>                    | Threaded insert UNC 1/4"                             |         |
| <b>Antenna factor</b>                     | +10 dB/m nominal                                     |         |
| <b>Operating temperature</b>              | -10 °C to 60 °C                                      |         |
| <b>Operating humidity</b>                 | 0 to 98% RH (without condensation)                   |         |
| <b>Storage temperature</b>                | -30 °C to 75 °C                                      |         |
| <b>Dimensions and weights (W x H x D)</b> |  |         |
| <b>Box</b>                                | 133 x 115 x 133 mm                                   | 0,90 kg |
| <b>Counterpoise</b>                       | 600 x 1,5 x 600 mm                                   | 4,15 kg |
| <b>Rod RA-01 and RA-01-HV</b>             | Ø 19 x 1000 mm                                       | 0,45 kg |
| <b>Rod RA-01-MIL</b>                      | Ø 19 x 1041 mm                                       | 0,45 kg |
| <b>TOTAL (w rod ext.)</b>                 | 600 x 1156 x 600 mm                                  | 5,95 kg |

## 1.7 Main Features

**TABLE 1-2 Main features**

|  |
|--|
| <ul style="list-style-type: none"> <li>• CISPR 16, CISPR 12, CISPR 25, MIL-STD-461 and DO-160 fully compliant</li> <li>• Built-in wide band amplifier</li> <li>• Excellent flatness</li> <li>• Individual calibration</li> <li>• High rejection to 50 Hz</li> <li>• Rechargeable Ni-MH battery for extra longevity</li> <li>• Easy assembly</li> <li>• Tripod mounting adapter</li> <li>• Ruggedized aluminium case and rod, stainless steel counterpoise</li> </ul> |
|--|

**1.8 PMM RA-01 parts**

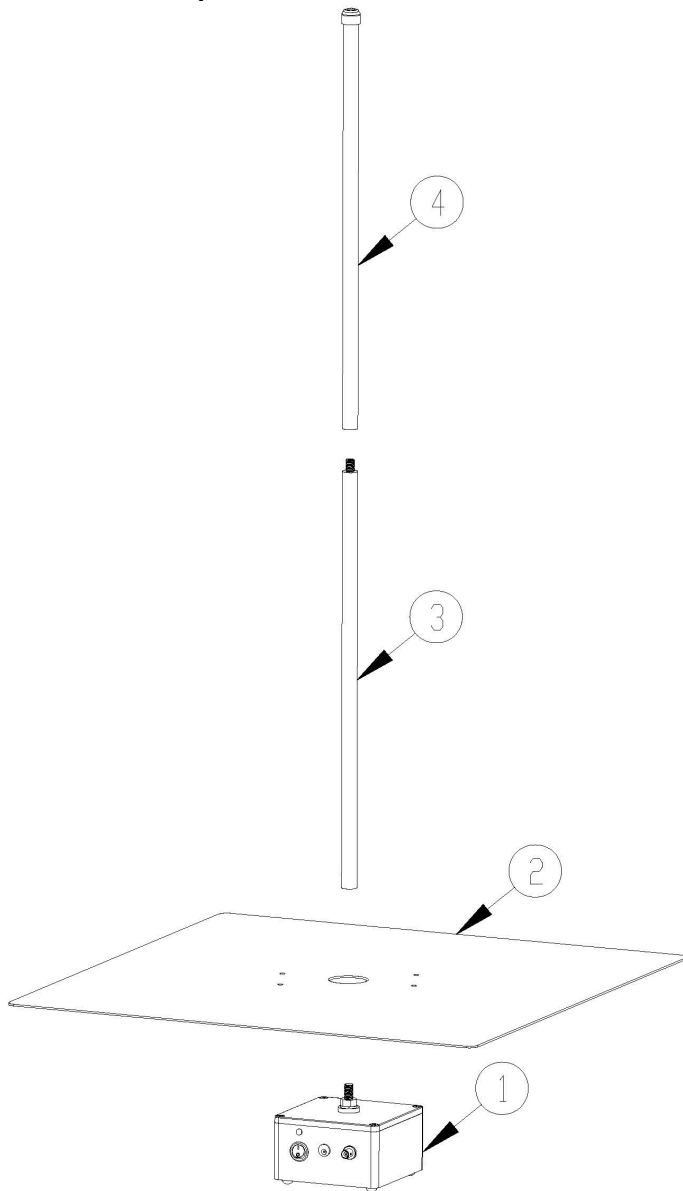

**Legend:**

- 1 – Box Pre-Amplifier and Adapting impedance
- 2 – Counterpoise
- 3 – Monopole antenna with the male thread
- 4 – Monopole antenna

**Fig. 1-2 PMM RA-01 parts**

**RA-01 box front view**

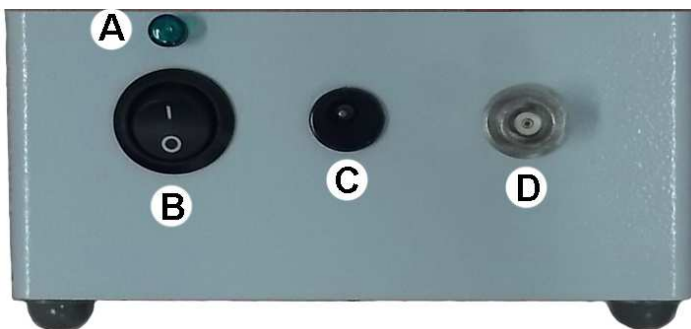

**Legend:**

- A= ON/OFF Switch
- B= Power LED
- C= Battery Charger connector
- D= BNC female connector

**Fig. 1-3 PMM RA-01 front view**

## 2 – Mounting Instructions

### 2.1 Introduction

This section provides the information needed to install and use your PMM RA-01 Active Rod Antenna.

Included are information pertinent to initial inspection, interconnection, environment, mechanical mounting, cleaning, storage and shipment.

### 2.2 Initial inspection

Inspect the shipping container for damage.



**If the shipping container or cushion material is damaged, it should be kept until the contents of the shipment have been checked for completeness and the antennas have been checked mechanically and electrically.**

**Verify the accessories availability in the shipping referring to the accessories check list enclosed.**

**Notify any damage to the carrier personnel as well as the NARDA Representative.**

### 2.3 Environment

The Rod antennas are made with lightweight corrosion-resistant aluminum providing years of indoor and outdoor service.

### 2.4 Return for service

If the PMM RA-01 Active Rod Antenna should be returned to NARDA for service, please complete the service questionnaire enclosed with the Users Manual and attach it to the instrument.

To minimize the repair time, be as specific as possible when describing the failure.

If possible, reuse of the original packaging to ship the equipment is preferable.

In case other package should be used, ensure to wrap the instrument in heavy paper or plastic.

Use a strong shipping container and use enough shock absorbing material around all sides of the equipment to provide a firm cushion and prevent movement in the container.

Seal the shipping container securely.

Mark the shipping container FRAGILE to encourage careful handling.



**Nowadays there are restrictions on the shipment of hazardous materials, eg. some types of lithium batteries.**

**Please, check the proper, safe, shipping mode, with the help of your courier, in the case the product is equipped with batteries.**

### 2.5 Equipment cleaning

Use a clean, dry, non abrasive cloth for equipment cleaning.



**To clean the wooden tripod do not use any solvent, thinner, turpentine, acid, acetone or similar matter to avoid damage to it.**

**2.6 PMM RA-01 Mounting Instructions** Remove two screws from the box as shown below.

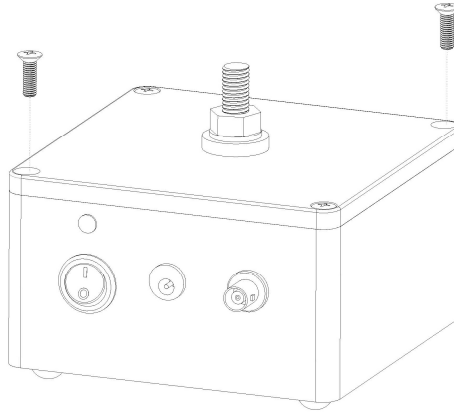

Install the Counterpoise to the box with the side “untouched” on the top (used the two screws removed previously).

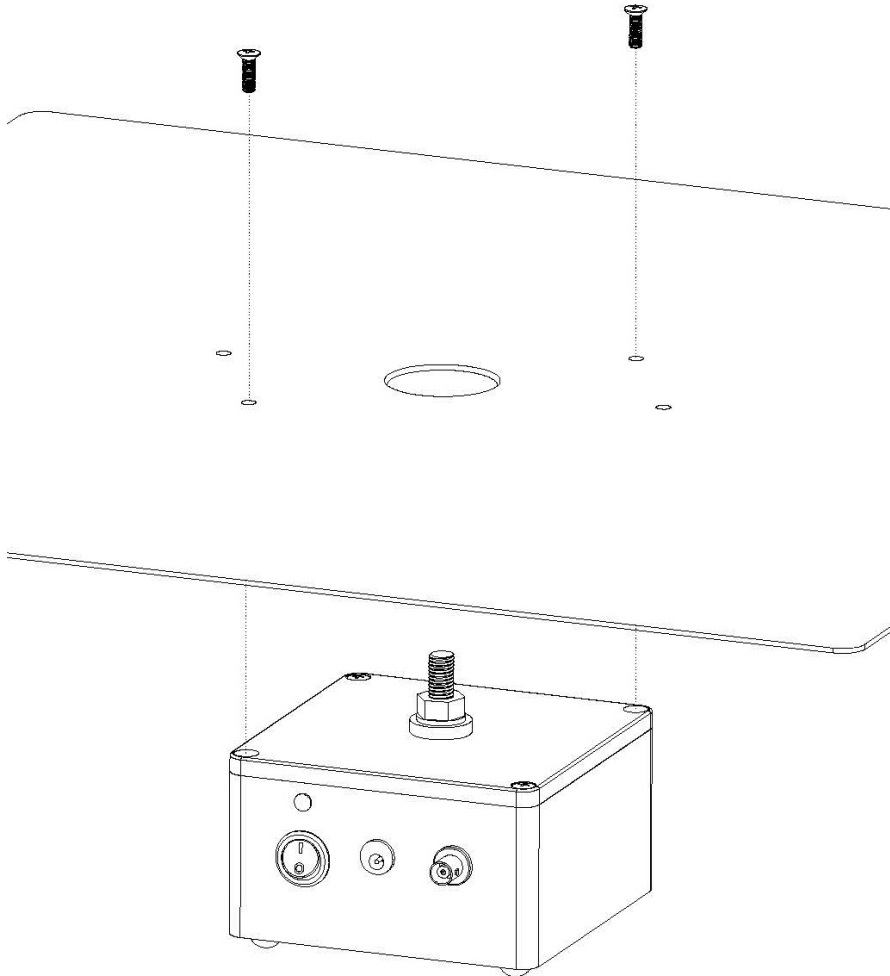

Screw the monopole antenna (with male thread) to the box.

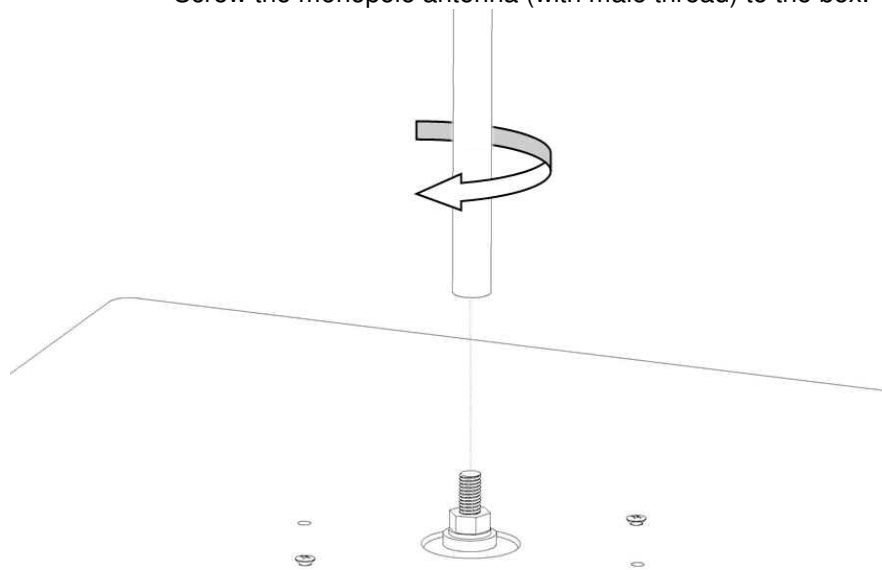

Screw a second monopole antenna to male thread

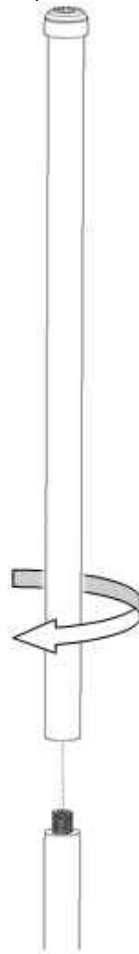

To Install the RA-01 on the TR-01 optional accessory see chapter 4

**This page has been left blank intentionally**



## 3 – Using PMM RA-01

### 3.1 How it works

PMM RA-01 is an active, high sensitivity Electric field receiving antenna. It has a built in preamplifier. It works as a short monopole over a ground plane. Its intrinsically high impedance within the covered frequency band is transformed and normalized by the internal preamplifier.

### 3.2 Power switch

To turn the unit on and off push the black switch located on the side panel of the box.

### 3.3 Battery charging

When the unit is on, the light from the green led placed inside the power switch indicates the remaining charge of the internal battery. So the light becomes weak when the battery voltage goes down. In this case the battery needs to be recharged. To charge the internal battery: switch the unit off, then plug the supplied AC battery charger in the supply mains and connect the apposite connector to the ROD box.



**In order to safeguard the features of the batteries, it is recommended to fully recharge it before using the antenna. Do not charger for more than 6 hours.**



**It is warmly suggested to recharge the batteries at least every 4 months even though the device has not been used.**

### 3.4 ESD risks



**Since the monopole terminal is directly connected to the high sensitive preamplifier, built using a delicate Field Effect Transistor, it is important not to touch it before proper grounding and being sure to avoid ESD effects.**

**The static charge carried by test personnel can damage the FET.**

### 3.5 Principles of operation

The most important assumption to be done concerns the length of the monopole. If it is short enough, and it means less then 1/8 wavelength at the higher frequency of the covered band, the current distribution over the antenna can be approximated to be linear.

The 1m length makes easy to calculate the field strength that is usually measured as Volts per meter. It is only necessary to take in count of the effective length of the antenna that is a half of its physical length. This means that a +6dB must be added to antenna factor when electric field strength is measured. In the meantime this length corresponds to a 1/8 wavelength at the frequency of about 37MHz, so it is possible to use it up to more then 30MHz. The ideal situation to use a rod antenna is when it operates in reference to an infinite ground plane. The small box containing the preamplifier should be connected to the real ground. If the case is not well grounded important reading differences can appear.

The RA-01-HV model is protected from low-frequency disturbance signals by internal 150 kHz High Pass Filter (for example: Main Power 50/60 Hz)



**If radiated by electromagnetic fields higher than 5kV/m 50/60 Hz, the antenna can be damaged**



**Please do not touch the Display of 9010F while using RA-01, in order to prevent measured E-field from being affected by wrong contribution through human body radiation**

### 3.6 Antenna factor

PMM RA-01 is supplied with individual antenna factor calibration data. The antenna factor is the ratio of the field strength in which the antenna is immersed to the voltage coming out of the unit. A typical value for Rod antenna factor is about +10dB. If, for example, the output of the antenna is +44dB $\mu$ V, and the antenna factor is +10dB at the radiated frequency, the electric field magnitude is: +44 +10 = **+54** dB $\mu$ V/m corresponding to **0.0005** V/m.

### 3.7 Procedure of Calibration

PMM RA-01 is calibrated in accordance with the equivalent capacitive substitution method, using equipment which certifications traceability to national and international standards are reported on the antenna certificate itself.

## 4 - Accessories

### 4.1 Introduction

This section provides the information required for installing and using the accessories of the PMM RA-01 Active Rod Antenna. Information is included regarding initial inspection, power requirements, interconnections, work environment, assembly, cleaning, storage and shipment.

The following general information is applicable to all accessories.

### 4.2 Preliminary inspection

Inspect the packaging for any damage.



**If the packaging or anti-shock material have been damaged, check that the contents are complete and that the meter has not suffered electric or mechanical damage.**

**Check that all the Accessories are there against the checklist found with the apparatus.**

**Inform the carrier and NARDA of any damage that has occurred.**

### 4.3 Work environment

Unless otherwise specified, the work environment of the Accessories, must come within the following conditions:

- Temperature From -10°C to +60° C
- Humidity (without condensation) < 98% relative

The Accessories must be stored in a clean and dry environment, free from dust, acids and humidity.

The storage environment must come within the range of the following conditions:

- Temperature From -30°C to + 75° C
- Humidity (without condensation) < 98% relative

### 4.4 Return for repair

When the Accessories need to be returned to NARDA for repair, please complete the questionnaire appended to this User's Manual, filling in all the data that will be useful for the service you have requested.

For reducing the period of time required for the repairs, it is necessary to be as specific as possible in describing the problem. If the problem only occurs in certain circumstances, please describe in detail how it happens.

If possible it is better to reuse the original packaging; making sure that the apparatus is wrapped in thick paper or plastic.

Otherwise, use strong packaging by using a sufficient quantity of shock absorbent material around all sides of the meter to ensure that it is compact and does not move around inside the package.

In particular, take every precaution to protect the front panels.

Finish the package by sealing it up tightly.

Apply a FRAGILE label to the package to encourage greater care in its handling.

### 4.5 Cleaning

Use a dry, clean and non-abrasive cloth for cleaning the instruments.



**Do not use solvents, acids, turpentine, acetone or other similar products for cleaning the devices in order to avoid damaging them.**

4.6

***PMM TR-01A Set (optional)***

4.6.1 TR-01A Set

Using the TR-01A Set, the antenna height can be adjusted so that the counterpoise is level with the ground plane height (80-90 cm, or 100 cm above the floor, depending on the standard); or, the antenna can be lowered so that the center point of the rod element is 120 cm above the chamber floor, as required by MIL-STD-461G.

The PMM TR-01A Set includes:

- TR-01 Tripod Wooden tripod with extension
- Column strengthener
- Soft carrying case

**TABLE 4-1 PMM TR-01 Wooden tripod with extension Specifications**

| Characteristics         | Performance Limits             |
|-------------------------|--------------------------------|
| • Legs                  | 3 legs x 3 sections extensible |
| • Transportation width: | 76 x 12 x 12 cm                |
| • Minimum height:       | 60 cm                          |
| • Maximum height:       | 180 cm                         |
| • Weight                | 2,8 kg                         |
| • Load capacity:        | 10 kg                          |



**Fig. 4-1 PMM TR01 Wooden Tripod**

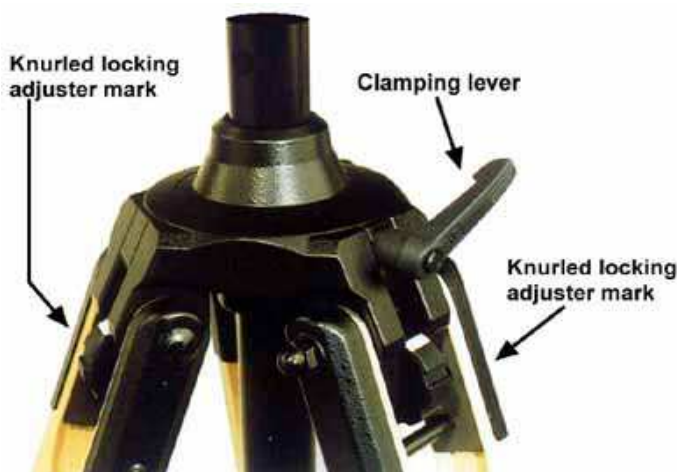

**Fig. 4-2 Adjustable joint**

It is possible to adjust legs spread at tree different angles, the adjustment is made rotating the knurled locking adjuster by selecting the corresponding marker on the knurled locking adjuster:

- 20° spread: knurled locking adjuster white mark;
- 45° spread: knurled locking adjuster red mark;
- Variable spread: knurled locking adjuster unmarked.

The central mast can be adjusted and fixed with the clamping lever.

**TABLE 4-2 Column strengthner Specifications**

- Dimensions                      Ø50 x 80 mm
- Weight                            184 g
- Load capacity                 10 kg

The Column strengthner allows to mount the RA-01 on the PMM TR-01 Wooden tripod with extension



**Fig. 4-3** Column strengthner

**TABLE 4-3 Soft carrying case Specifications**

- Dimensions                      Ø160 x 900 mm

The Soft carrying case allows to carry the TR-01A Set on the site



**Fig. 4-4** Soft carrying case

#### 4.6.2 RA-01 installation on TR-01A Wooden tripod

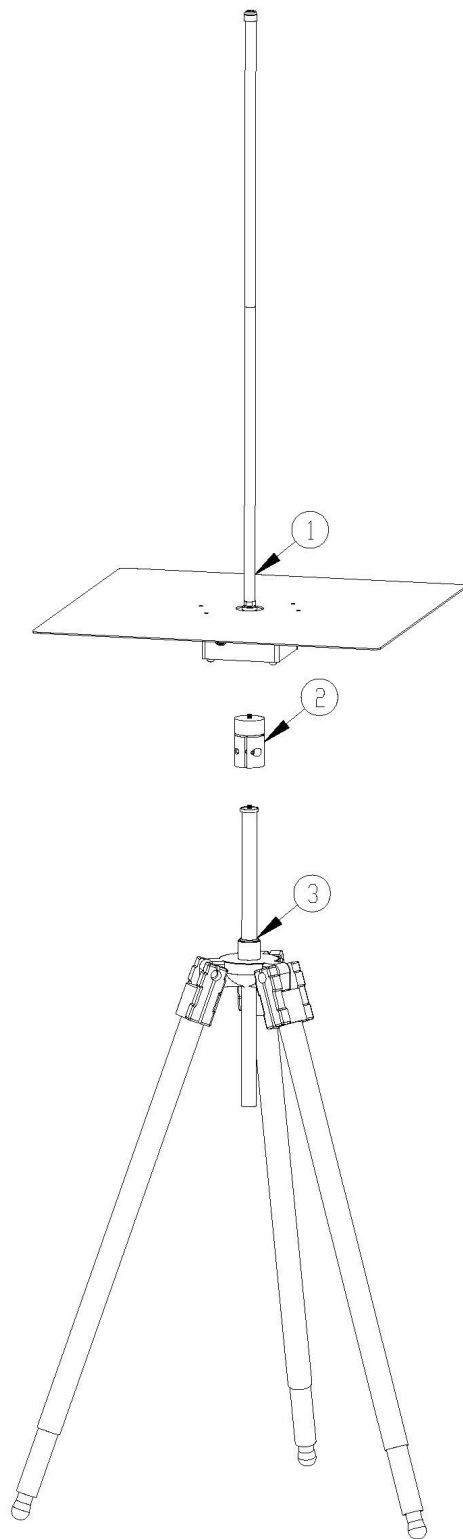

**Legend:**

1 – RA-01

2 – Column strengthener

3 – PMM TR01 Wooden Tripod

**Fig. 4-5** RA-01 parts and assembly

Unscrew the pan-head screw from Column strengthener without losing it completely.

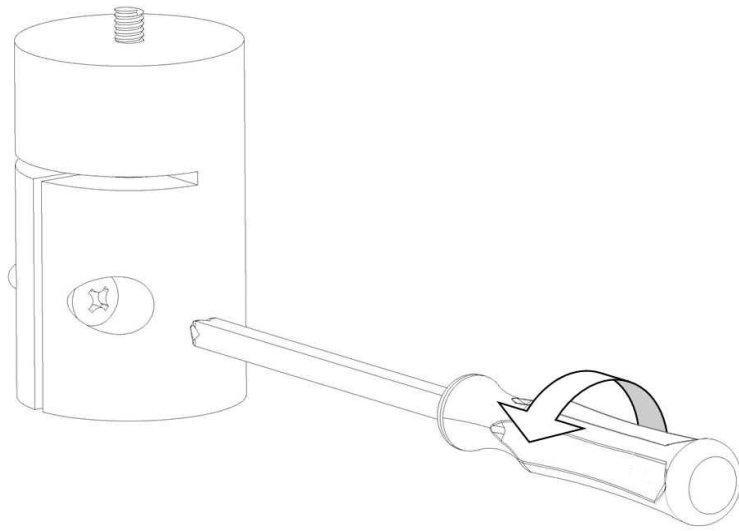

Screw the Column strengthener on the RA-01 bottom; be sure that it is well locking

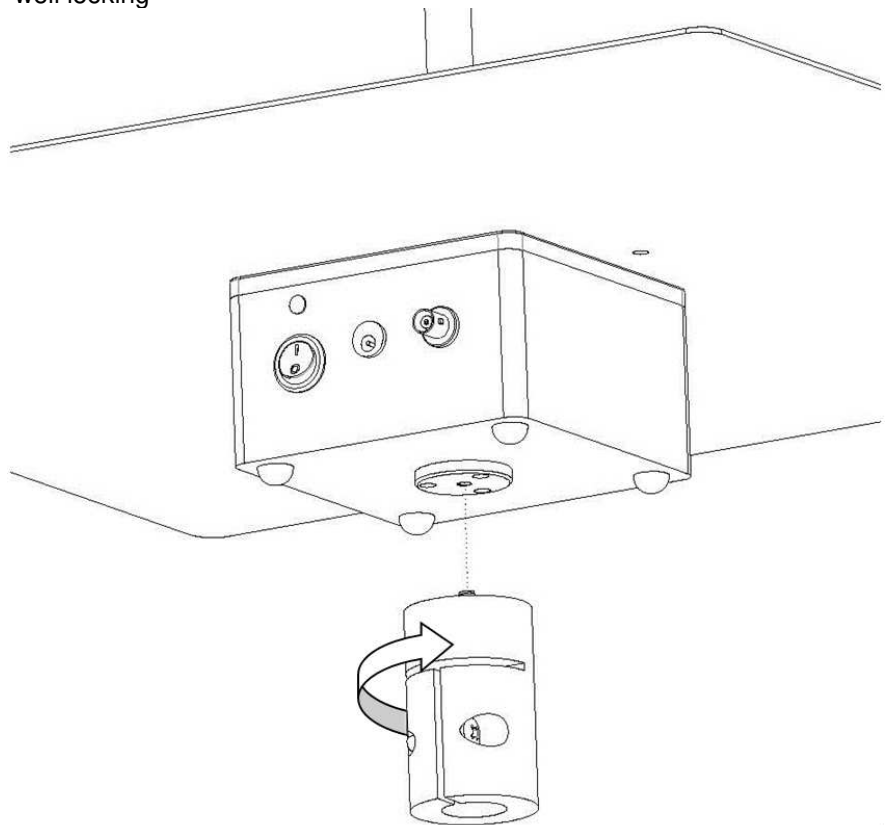

Unscrew the plastic washer removing it completely from the TR-01.

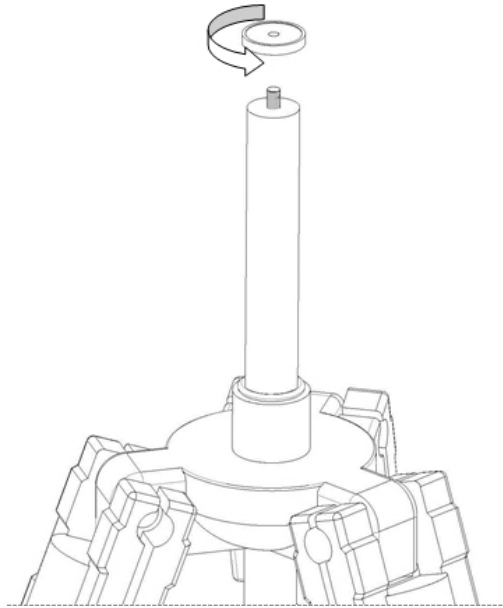

Install the PMM TR-01 Wooden Tripod on the site.

Insert the Column strengthener (fixed to RA-01) on the wooden extension and make sure it is fully inserted, then screw the pan-head screw (be sure that it is well locking).

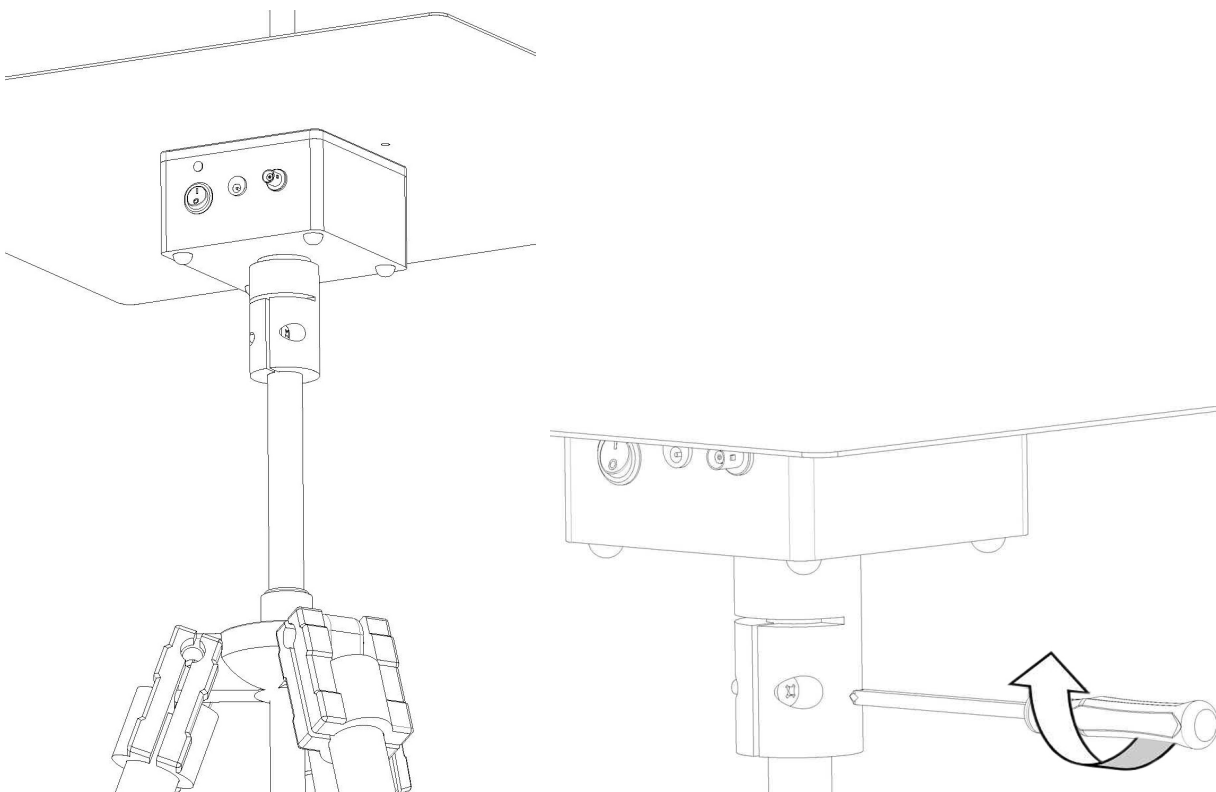



**Caro cliente**

grazie per aver acquistato un prodotto NARDA! Sei in possesso di uno strumento che per molti anni ti garantirà un'alta qualità di servizio. NARDA riconosce l'importanza del Cliente come ragione di esistenza; ciascun commento e suggerimento, sottoposto all'attenzione della nostra organizzazione, è tenuto in grande considerazione. La nostra qualità è alla ricerca del miglioramento continuo. Se uno dei Suoi strumenti NARDA necessita di riparazione o calibrazione, può aiutarci a servirla più efficacemente compilando questa scheda e accludendola all'apparecchio.

Tuttavia, anche questo prodotto diventerà obsoleto. In questo caso, ti ricordiamo che lo smaltimento dell'apparecchiatura deve essere fatto in conformità con i regolamenti locali. Questo prodotto è conforme alle direttive WEEE dell'Unione Europea (2002/96/EC) ed appartiene alla categoria 9 (strumenti di controllo). Lo smaltimento, in un ambiente adeguato, può avvenire anche attraverso la restituzione del prodotto alla NARDA senza sostenere alcuna spesa. Può ottenere ulteriori informazioni contattando i venditori NARDA o visitando il nostro sito Web [www.narda-sts.it](http://www.narda-sts.it).

**Dear Customer**

thank you for purchasing a NARDA product! You now own a high-quality instrument that will give you many years of reliable service. NARDA recognizes the importance of the Customer as reason of existence; in this view, any comment and suggestion you would like to submit to the attention of our service organization is kept in great consideration. Moreover, we are continuously improving our quality, but we know this is a never ending process. We would be glad if our present efforts are pleasing you. Should one of your pieces of NARDA equipment need servicing you can help us serve you more effectively filling out this card and enclosing it with the product.

Nevertheless, even this product will become obsolete. When that time comes, please remember that electronic equipment must be disposed of in accordance with local regulations. This product conforms to the WEEE Directive of the European Union (2002/96/EC) and belongs to Category 9 (Monitoring and Control Instruments). You can return the instrument to us free of charge for proper environment friendly disposal. You can obtain further information from your local NARDA Sales Partner or by visiting our website at [www.narda-sts.it](http://www.narda-sts.it).

**Servizio richiesto:**  *Service needed:*

Solo taratura     Riparazione     Riparazione & Taratura     Taratura SIT     Altro:  
 Calibration only     Repair     Repair & Calibration     Certified Calibration     Other:

**Ditta:**

*Company:*

**Indirizzo:**

*Address:*

**Persona da contattare:**

*Technical contact person:*

**Telefono:**

*Phone n.*

**Modello:**

*Equipment model:*

**Numero di serie:**

*Serial n.*

**Accessori ritornati con l'apparecchiatura:**  Nessuno     Cavo(i)     Cavo di alimentazione    **Altro:**  
 *Accessories returned with unit:*     None     Cable(s)     Power cable    **Other:**

**Sintomi o problemi osservati:**  *Observed symptoms / problems:*

**Guasto:**  Fisso     Intermittente    **Sensibile a :**  Freddo     Caldo     Vibrazioni     Altro  
 *Failure:*  Continuous     Intermittent    *Sensitive to:*  Cold     Heat     Vibration     Other

**Descrizione del guasto/condizioni di funzionamento:**

*Failure symptoms/special control settings description:*

**Se l'unità è parte di un sistema descriverne la configurazione:**

*If unit is part of system please list other interconnected equipment and system set up:*

